

NEA NUCLEAR INNOVATION 2050

R&D COOPERATIVE PROGRAMME PROPOSAL

NUCLEAR REACTOR DISMANTLING DEMONSTRATOR

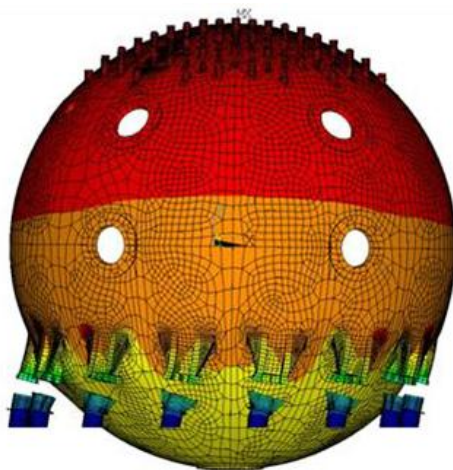
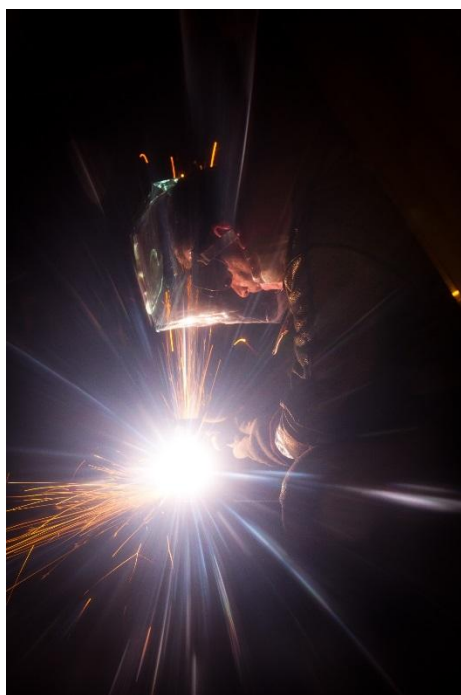

SUMMARY

1.	FOREWORD	3
2.	INTRODUCTION	4
2.1.	GENERAL CONTEXT	4
2.2.	FRENCH GRAPHITE REACTORS INNOVATIVE DECOMMISSIONING STRATEGY	5
3.	JUSTIFICATION OF THE NUCLEAR REACTOR DEMONSTRATOR PROJECT AS THE SELECTION	7
3.1.	DECOMMISSIONING DEMONSTRATOR DESCRIPTION	11
4.	THE ISSUE TO TACKLE AND OBJECTIVES TO REACH	16
5.	WHAT IS DONE/EXIST ALREADY, WHO IS DOING WHAT, WHAT ARE THE MEANS	17
5.1.	AVAILABLE INTERNATIONAL EXISTING MEANS AND OPEX	17
5.2.	INTERNATIONAL EXISTING COLLABORATION	17
5.3.	ALREADY AVAILABLE DATA AND PRESENT STATUS OF THE DEMONSTRATOR PROJECT	17
5.4.	MORE RECENT INTERNATIONAL EXCHANGES	20
6.	WHAT CAN BE DONE TO IMPROVE/ACCELERATE, IA THROUGH COOPERATION	21
6.1.	INTERNATIONAL COOPERATION	21
6.2.	PARTNERSHIPS	22
7.	PLAN OF ACTIONS AND NECESSARY MEANS	23

2. FOREWORD

This template presented in the frame of the NEA NI 2050 initiative by the Waste management and Decommissioning Group aims to embed, within the OECD/NEA activities, an emerging multinational project of nuclear decommissioning demonstrator.

This demonstrator was first motivated by EDF change of strategy for its French graphite reactors.

It was first initiated to assess and secure decommissioning scenarios, associated schedule/planning and costs as well as innovative methods. It will enable the use of remote handling tools, operators training, as well as settlements and adjustments to be identified and tested in order to face unavoidable and unexpected situations that will undoubtedly occur as all reactors being dismantled nowadays in the world have never been designed to be decommissioned one day, particularly graphite types ones.

This project of demonstrator facility aims also to meet the worldwide identified needs to mitigate risks, increase safety, stakeholders' confidence and public acceptance.

This objective is to be reached by demonstrating the efficiency of new techniques enabling to optimise waste, reduce the amount of secondary ones (ashes, releases, ...) but also improving packaging, cutting speeds thanks to several former scenarios and tests giving the opportunity to select in advance the right tools and means as well as to train operators, on remote handling tools, in safe conditions, before being put in real ones.

This template describes the global international context and reflexions that have led to present and submit to the NEA NI2050 Advisory Panel this prior EDF initiative of a nuclear reactor dismantling demonstrator that has met multinational concerns and gathered an already commitment between several countries partners.

An NEA approval or support will certainly allow more operators from various countries to become counterparts of this project.

The conception of this facility, based on a voluntarily modular design, enables to extrapolate its further use to any kind of nuclear technology reactor to be dismantled worldwide.

This demonstrator, which is to be operational in 2022, will enable operators from several countries, to be trained, to share and test innovative solutions to solve their respective legacy concerns, by mastering techniques, increasing safety and environment considerations while reducing the duration of a decommissioning phase and associated costs.

3. INTRODUCTION

3.1. GENERAL CONTEXT

In January 2018, in not less than 30 countries, around 448 Nuclear Power Plants (NPPs) were still under operation and 157 had already been shutdown or dismantled. This worldwide context, characterized by the continuous and steady emergence of the field of decommissioning and legacy management issues has led to :

- Increasing expectations of civil society on nuclear safety, environmental protection, transparency and consultation about industrial projects and energy costs,
- Evolution of the regulatory framework towards greater transparency and involvement in the evaluation process,
- Waste management identified as a cornerstone of decommissioning and legacy management issues
- Financial and technical mastery of decommissioning scenarios and associated global strategies to keep and increase the nuclear industry credibility and sustainability.

In addition, it has to be kept in mind that NPPs' owners or operators are responsible for the safe and efficient running of each of the 3 phases which shapes the usual lifecycle of a nuclear facility such as :

- Design and conception
- Decades of operation
- Decommissioning.

In this general framework, EDF is one of the biggest Nuclear operator worldwide, involved in each of the 3 above phases and operating a fleet of approximately 80 NPPs in several countries, taking into account local national regulations, considerations and specificities.

In France, as NPPs owner/operator, EDF ensures its role through an architect integrator model all along the above 3 phases, applying, for each of them, the same quality considerations and level of requirements.

As a matter of consequence, EDF is :

- involved in the design and conception of NPPs in China, France, UK,
- operating nuclear fleets in France and UK,
- also in charge of the decommissioning of the French first generation of NPPs already shut downed as well as preparing the dismantling of the PWR fleet now still under operation.

Regarding Decommissioning, EDF has been actively involved in this field for nearly 20 years.

EDF is effectively ensuring the dismantling, in France, of 9 reactors from several nuclear technologies (1 Heavy Water Reactor, 1 Fast Breeder Reactor, 1 PWR, and 6 graphite reactors).

EDF has actually acquired a valuable experience in this field all over the years and throughout the different technologies to be taken into account.

Nevertheless, EDF is steadily concerned about strengthening its technical and financial mastery in decommissioning while increasing stakeholders' confidence and public acceptance.

For this purpose, EDF is continuously seeking the best means to improve its scenarios, to optimize its methods and tools and add value and positive impact on safety, waste management, environment, efficiency thanks to all kinds of actions securing the schedule and enabling cost reductions.

In order to bring together know-how, skills, competences, technical and economical means and resources in the emerging fields of decommissioning and waste management, EDF group has decided, in 2015, to create a devoted Direction : DP2D (Decommissioning Projects and Waste management Direction).

This direction gathers not only EDF decommissioning projects with associated human resources and expertise but also EDF waste treatment facilities spread over 3 countries and specially embedded in a dedicated holding named Cyclife.

3.2. FRENCH GRAPHITE REACTORS INNOVATIVE DECOMMISSIONING STRATEGY

As soon as DP2D was created in 2015, the teams in charge were given the aim of identifying new potential productivity gains as well as remaining issues and to find appropriate solutions or means to solve them or to optimise the existing ones.

Regarding the decommissioning of the 6 french Graphite reactors, the immediate dismantling strategy driven by the French law was based on the availability of a French graphite devoted disposal to be built by the national French organization in charge of radioactive waste management.

Beyond successive delays postponing this project facing constraints due to antinuclear opposition, EDF took the opportunity to improve its scenarios.

As a matter of fact, in France, following a national "as fast as possible" decommissioning strategy, 4 graphite reactors out of the 6, were supposed to be dismantled underwater and the 2 last ones in air.

In UK, EDF group is operating 14 Advanced Graphite Reactors which are about to prepare their decommissioning following the committed deferred strategy adopted by the British government.

EDF-DP2D, involved in both countries, decided to review and renew its graphite reactors decommissioning strategy in order to optimise tools, skills and to improve their efficiency as well as mastering costs.

It was therefore decided to decommission all 6 French graphite reactors in air, to allow mutualisation of techniques and scenarios amongst each of them.

Based on this first assumption, during the year 2016, DP2D teams identified all remaining issues and conducted an international benchmark process, particularly with neighborhood countries involved in graphite decommissioning (UK, Spain, Italy...).

Throughout the exchanges and experiences shared, it appeared that some of the noticed concerns (i.e. potential blockage of graphite sleeves, their potential fragilisation due to irradiation process preventing from extracting them easily, ...) had been foreseen or not, but, in any case , no real solutions had been actually tested nor fully qualified, even abroad.

EDF detailed studies showed that the duration of the underwater operations was longer than initially foreseen. Several issues and risks became more significant like tightness, corrosion, secondary wastes amount,...

Beyond these aspects, it became notable that some other unexpected situations will certainly be faced during the effective decommissioning process as none of the existing operated reactors worldwide, whatever is their nuclear technology, have been designed to be dismantled one day. This is even more the case of graphite types ones due to their design imposing a different maintenance and components replacement policy.

As a matter of consequence, EDF DP2D built a new sensible decommissioning scenario which was presented and assessed by the French regulator in June 2017. Chinon A2 site reactor was chosen to be the first to be dismantled according to a multi-criteria analysis. As part of this analysis, Chinon A2 is also as the most representative of the European graphite reactors as well as some Asian ones.

As in any breakthrough situation, EDF was obviously asked to demonstrate the feasibility and advantages of its new scenarios and associated innovative techniques, enabling to increase safety, workers efficiency and work conditions, minimize collective exposure doses and releases, optimize secondary waste generation and handling procedures. Furthermore, the series of tests to be performed within the testing facility will allow to optimize the design and the performances of the main dismantling tool which is the dismantling platform and the associated confinement system.

As a consequence, EDF developed a progressive approach to secure decommissioning operations, particularly through the project of the construction of an industrial demonstrator, prior to the real decommissioning of Chinon A2.

4. JUSTIFICATION OF THE NUCLEAR REACTOR DEMONSTRATOR PROJECT AS THE SELECTION

Graphite type reactor was the main option at a time where the enrichment of uranium was not mastered and where graphite as a moderator was preferred to heavy water, (...) for economical reasons. At that time France and UK developed in parallel the UNGG and the Magnox. When EDF and CEA were designing Chinon A2, the collaboration between the 2 countries was very close. Some reactors of this family were also exported to Italy, Spain and Japan.

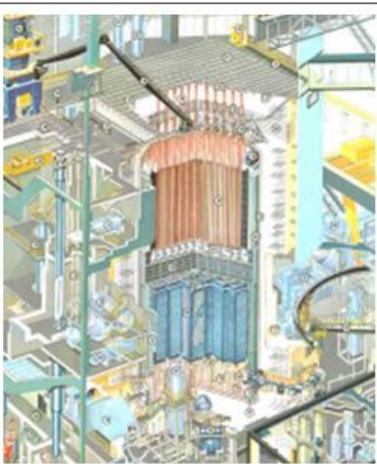

Saint-Laurent (F) -
Vandellos (Spain)

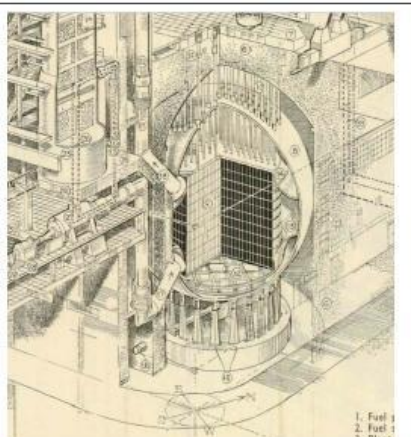

Bradwell (UK)

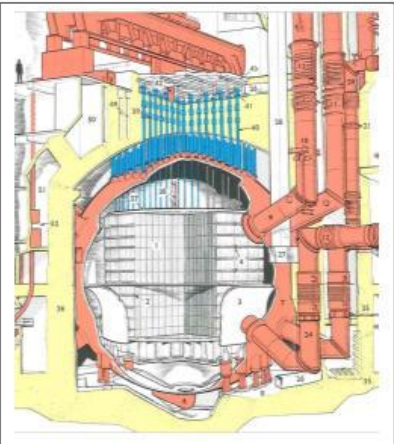

Latina (Italy)

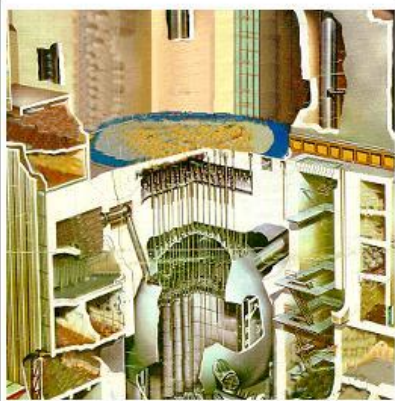

Chinon A2 (France)

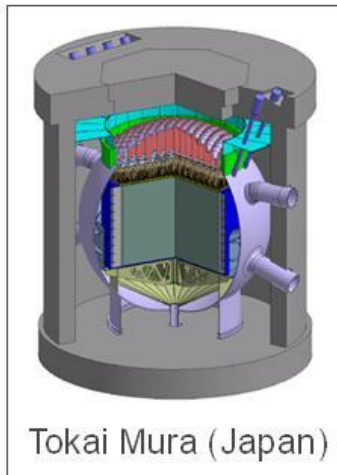

Tokai Mura (Japan)

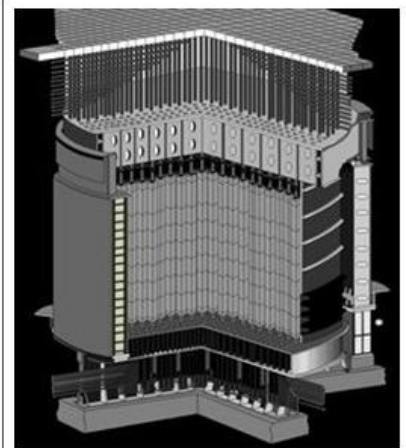

RBMK (Ukraine)

Russian designed Graphite reactors (RBMK) are slightly different but, several dismantling issue specially concerning graphite are common.

The map below shows the reactors already shut down. The following countries are specially concerned by graphite reactors : United Kingdom (26 stopped and 14 operating), France : (9), Germany (2), Italy (1), Spain (1), Russia (9), Ukraine 4, Lithuania (2), Japon (1), USA (1)



The demonstrator facility, aim of this selection within the NI 2050 initiative, may become a place for international collaboration between organization / countries involved in reactors dismantling activities : France, UK, Germany, Italy, Spain, Japan, Russia, Lithuania, etc.

This Industrial Demonstrator can be used to test tools and methodologies for other French UNGG, but also for all other graphite reactors in the world.

Whether the reactors are still in operation, already stopped and / or in the dismantling phase, all these operators are concerned by the dismantling of graphite-gas reactors and have little international experience feedback.

Upon more than 50 graphite reactors stopped to date in the world, only 2, smaller, are completely dismantled (Fort Saint Vrain in USA and WAGR in UK).

Unfortunately, the available Opex gathered from these 2 worksites experiences, rely on too old technologies, done at a smaller scale (scale factor > 10 on main operations) and may not even be useful considering new regulatory and environmental constraints or evolutions up to date.

At the opposite, the industrial demonstrator facility has been designed to test remote handling tools and dismantling scenarios in a collaborative track. Its modular conception enables to evolve as needed, all along the years.

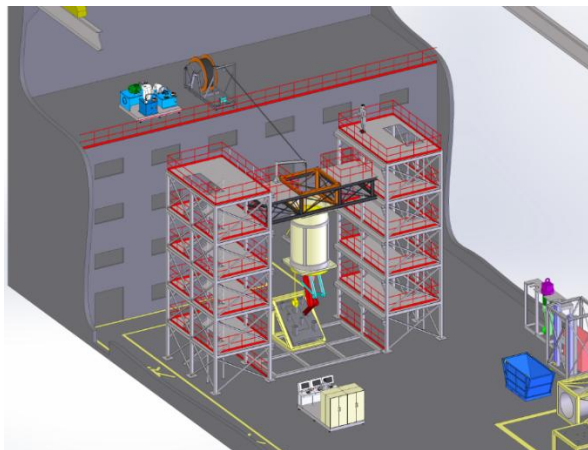

First Motivated by EDF change of strategy regarding graphite reactors dismantling, it was to be designed as a modular concept, enabling operators to extrapolate later to other kind of nuclear technologies, implementing safely innovative techniques and training themselves.

This nuclear reactor decommissioning demonstrator has been initiated to assess and secure decommissioning scenarios, remote handling tools, operators training, adjustments to be identified and tested in order to face unavoidable and unexpected situations that will undoubtedly occur.

There is also a need to optimize waste, to reduce secondary waste but also to improve packaging, cutting speeds by being able to select in advance the right tools and means and to train operators in safe conditions before being put in real ones.

All these aspects are part of the global roadmap of tests being foreseen in order to enable to improve the global technical and financial decommissioning mastery by mitigating risks in operation.

Instead of identifying the needs one after the other, it can provide operators from several nuclear companies, different cultures to share a facility, to test tools enabling to reduce risks of the innovation process by solving challenges through pre competitive international cooperation.

To ensure to take into account all aspects, EDF organized an international workshop last October 2017. This meeting brought together French CEA, but also UK representatives (from the NDA, Magnox, environmental agency) and Spain (ENRESA). The NDA did confirm its interest as this scenario appeared to them as a better option to increase public acceptance in their Magnox decommissioning strategy.

An agreement signed between UK and French Governments last January 2018 on civil nuclear. Cooperation on graphite dismantling is integrated in this agreement and the demonstrator is part of the topics to be addressed.

In addition, EDF initiated this demonstrator firstly motivated by CHINON A2 dismantling but keeping in mind that CHINON A2 is the twin elder sister of Tokai Mura 1 in Japan.

As a consequence, this demonstrator could also be of interest for other countries like Italy, Japan or Russia, potentially Germany and Canada.

This is the main reason why the NI 2050 Waste management and Decommissioning Group suggested to submit it to the NEA within the NI 2050 initiative.

As briefly described in chapter 3.1, first drawings are already made including Spanish, British and Italian needs. but the dimensions of the demonstrator don't prevent it from being extrapolated and used for other kind of nuclear reactor to be dismantled.

Due to the importance of 3D modeling and remote handling tools facet, the close link of this project with the NEA next September 2018 workshop on robotics seems obvious.

It could be a win-win partnership for several countries, if NEA was promoting this project in the frame of NI 2050.

The demonstrator should be available in 2022 and used until 2032 to assess first Graphite reactors dismantling scenarios (or Candus as Canada said they were also interested).

After 2032, it could be used to assess decommissioning scenarios of other types of reactor technologies or to find solutions and train operators on unexpected situations that will have to be faced. It could be used as a platform to test and settle innovations in robotics and remote handling...

It's therefore in compliance with NI 2050 schedule.

The aim is really to test, train people to increase safety, mastering schedule, reducing costs, increase operators' efficiency and confidence and minimising dosimetry, secondary waste, ... It will enable to increase public acceptance and nuclear industry credibility.

This demonstrator project is a pragmatic approach which helps to solve problems, win efficiency, increase performance despite local regulations or countries policies discrepancies.

By supporting such a project which is already a commitment between 3-4 countries, all new counterparts may gain some advantages by being enabled to implement their own needs or scenarios. As counterparts, they will afford the use of a facility that doesn't exist yet worldwide sharing the same aim of increasing safety while reducing time and costs by improving operators and tools efficiency.

4.1. DECOMMISSIONING DEMONSTRATOR DESCRIPTION

This decommissioning Demonstrator Facility is being designed following large scale principles, in order to demonstrate and optimize the dismantlement scenarios of each type of nuclear reactor, starting with graphite reactors with EDF Chinon A2 as launch test.

The numerous risks listed in the dismantlement safety analysis associated to the complexity of the decommissioning processes for this type of reactors are mainly due to their dimensions, the compactness and presence of graphite.

This facility will be built to test, improve and optimize different known and innovative remote dismantling technologies up to the management of radioactive waste, physical tests being associated to digital models.

As a consequence, this facility is divided into 3 main parts :

- Large scale Experimental hall
- 3D modeling and digital platform with a direct view on the experimental hall,
- Offices and services

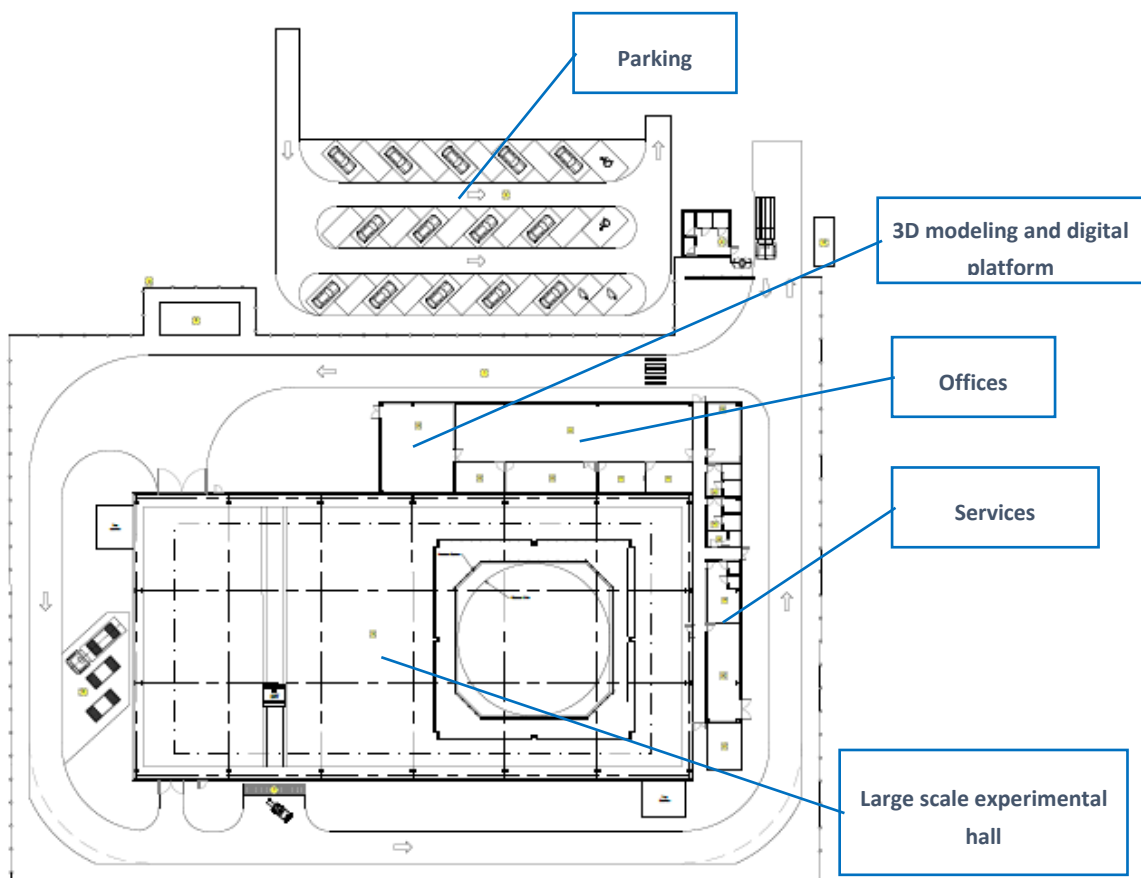

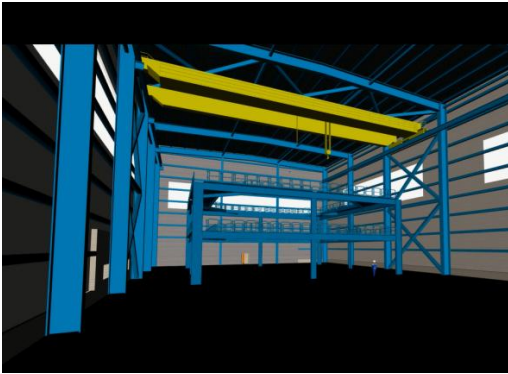

Testing Workshop

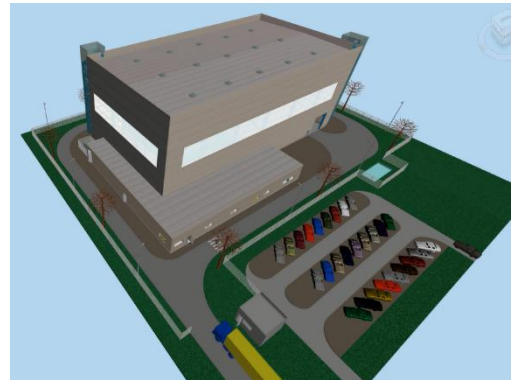

overall view

The facility will be constructed near the Chinon nuclear power plant. The building (20m high, 50m long, 30m large) will host :

- Physical simulators for metal and graphite structures dismantling risk mitigation operations :
 - Full scale mock ups of parts of the reactor will be used
 - Different zones of the building will host different simulators
- Digital simulators, 3D Modelling
- Services

Several large scale mock-ups are already foreseen to be installed and used for testing within the testing facility.

The representative mock-ups of specific sections of Chinon A2 reactor will allow to perform all necessary risk mitigation activities associated to the dismantlement scenario.

The facility will be then used for other reactors than Chinon A2 : Bugey 1, Chinon A3, Chinon A1 and St Laurent A1 and A2. The facility can also be used for other international graphite reactors.

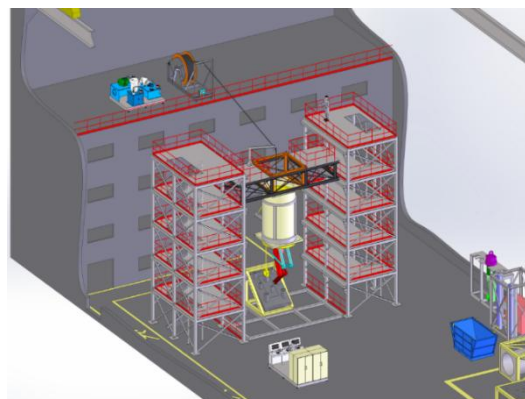
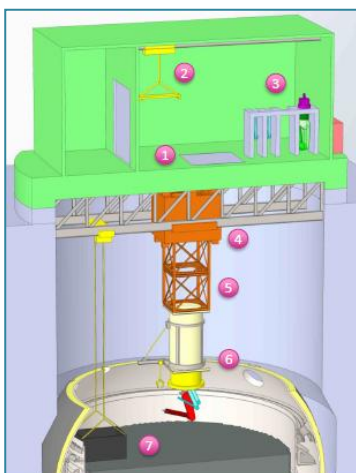

Example of an operation on the demonstrator and the equivalent on the reactor

Example of Graphite blocks extraction tests

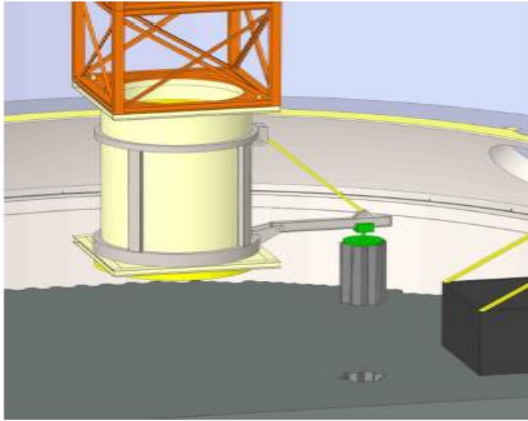

A possible scenario



Possible test in the testing facility

Tests on mock-up:

- Remote concrete cutting and drilling tools considering concrete characteristics and different configurations
- Remote handling of large concrete blocks
- Remote cutting and handling of thick metallic structures (vessel, peripherals, core support...)
- Handling the waste generated
- Graphite blocks (more than 25000) and graphite keys (more than 260000) extraction processes (including unfavorable cases)
- Asbestos management during vessel cutting (confinement)
- Managing the access of different tools to different zones within the reactor (long distances, video systems)
- Management of any unfavorable cases : broken or blocked tool - fall of structures, waste – structures deformation (shifting) or blocking
- Next steps : adapt the mock-ups to the specificities of other UNGG reactors (supporting deck including graphite for example).

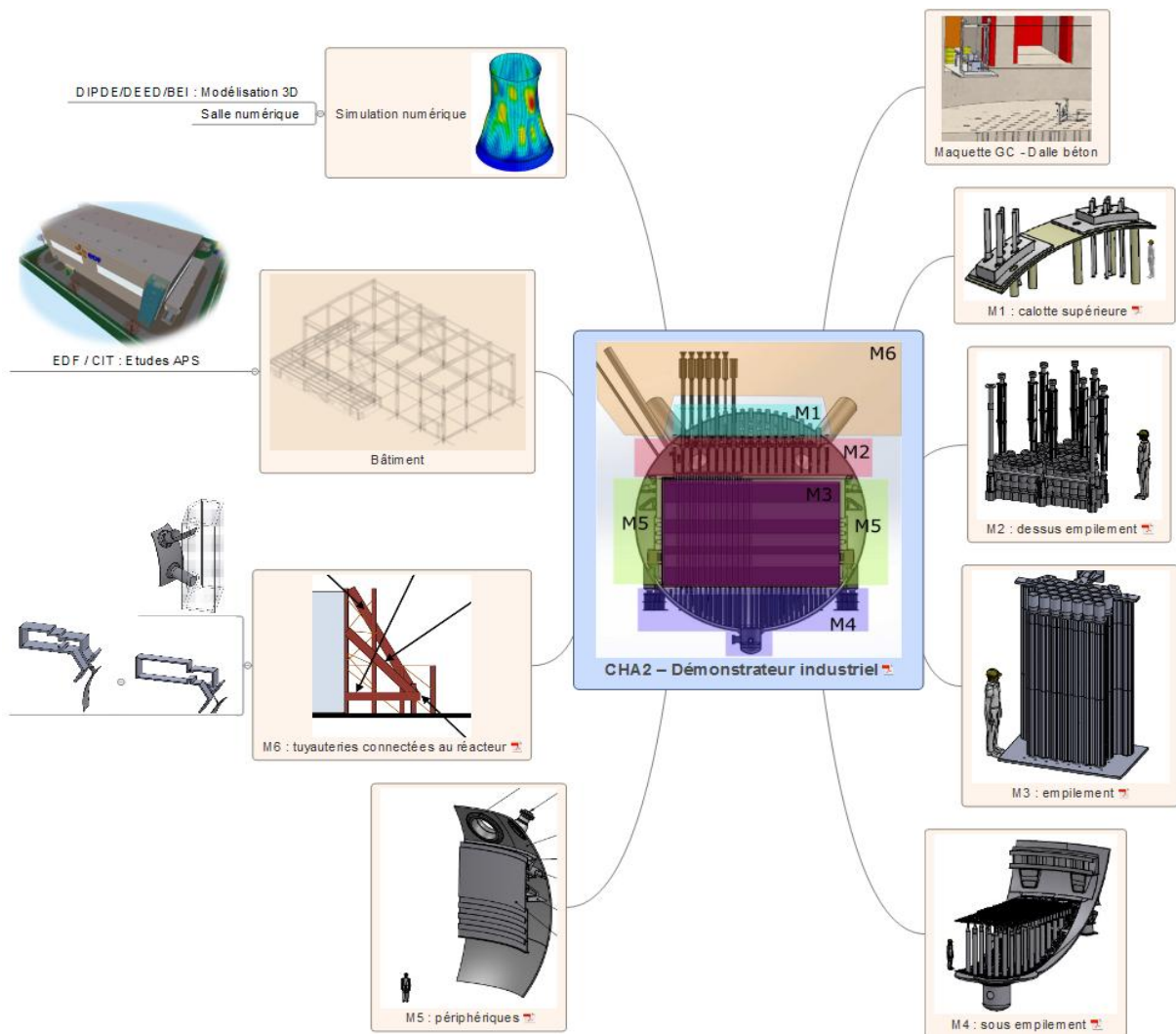

Examples of Mock-ups associated to CHINON A2 decommissioning scenario of internals

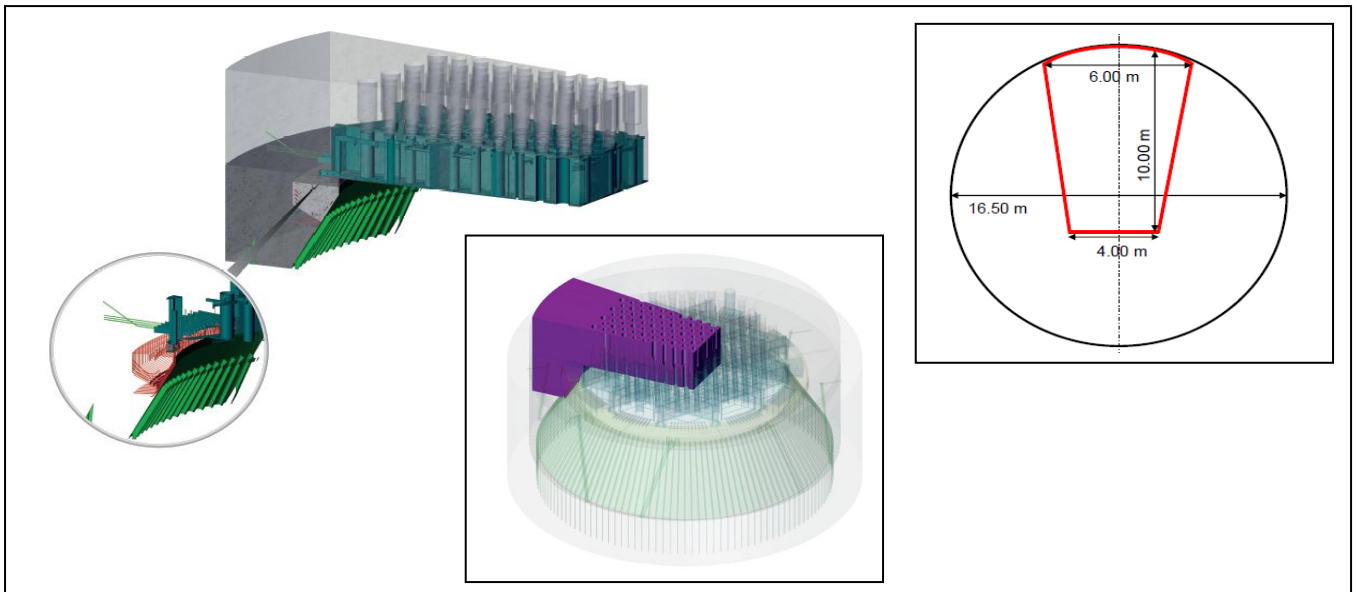

Examples of Mock-up associated to CHINON A2 decommissioning scenario of Upper concrete slab

Needs in numerical calculation / 3D models :

- Models to predict concrete behaviour (notably for pre-stressed reactors)
- Numerical calculation to predict the behaviour and ensure the stability of the spherical vessel, the corset and the supporting deck
- Assist the operators before (training), and during the dmt activities (corrections)
- Optimize the dismantling methodology and scenario

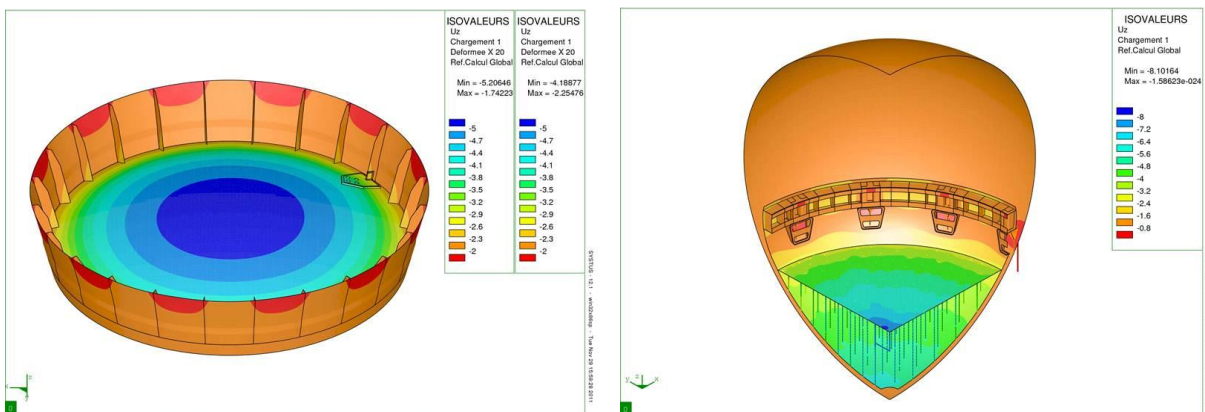

Numerical calculation : concrete opening and dismantling platform design

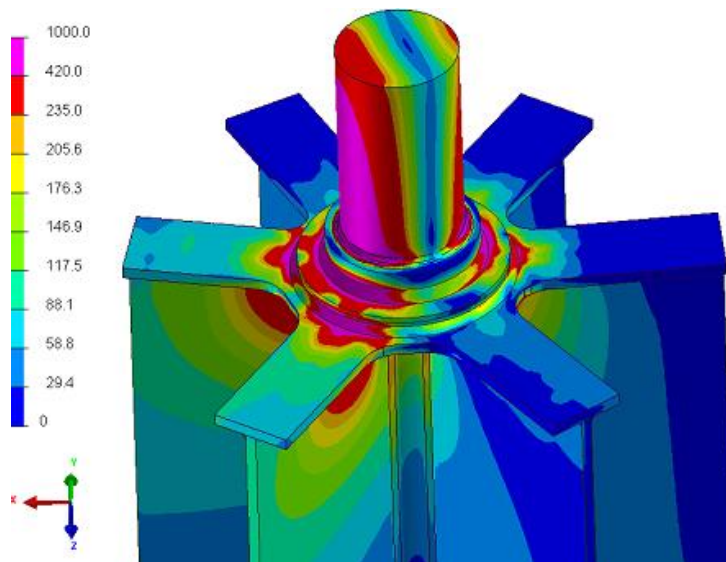

Seismic calculation

5. THE ISSUE TO TACKLE AND OBJECTIVES TO REACH

Chinon A2 reactor (CHA2) was selected to be the first from the six EDF Graphite Reactors to be dismantled.

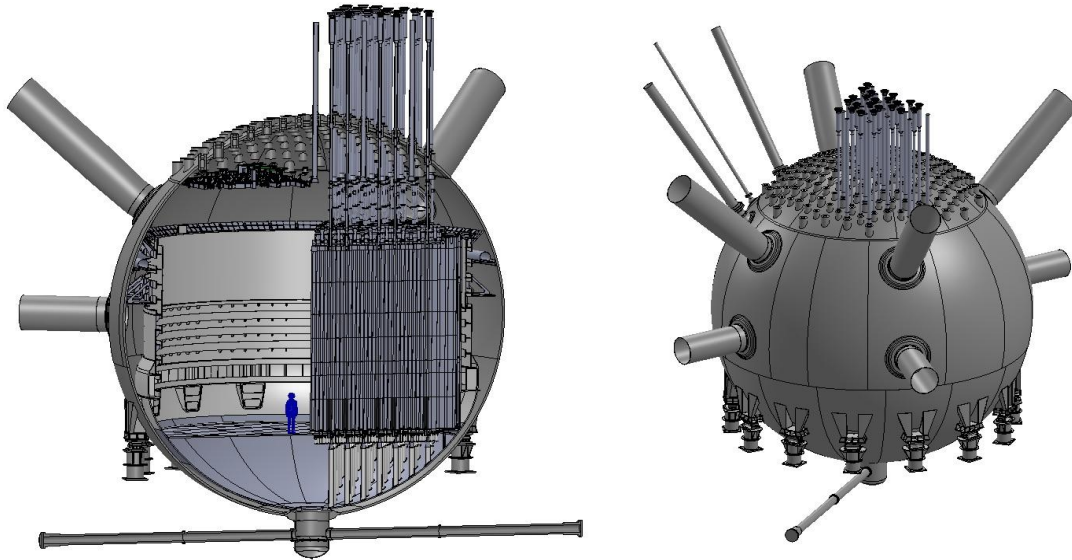

Main goals of the testing facility :

- Improve Nuclear **Safety** during dismantling activities notably by mitigating the risks in general and specifically securing dismantling duration when the vessel is opened
- Optimize **Radiation protection** and health and safety of the operators (alternative technics are tested and will be ready to use)
- Optimize primary and secondary Radioactive **Waste volumes**
- Optimize Dismantlement **Costs**

But the project will also participate in :

- Demonstrating the dismantling feasibility (normal configuration, degraded modes...)
- Qualifying the dismantling processes, optimizing their performance and limits
- Optimizing the dismantling scenario by testing alternative (innovative) technologies,
- Optimizing the design and the performance of the main dismantling tool which is the dismantling platform
- Accumulating data in order to increase and validate the numerical 3D models
- Personal Training, as close as possible to dismantling activities
- Back up operations in the event of a hazard during operations (rear base)

The testing facility may also be a great tool for communication, for personal involved in dismantling activities as well as for the public.

6. WHAT IS DONE/EXIST ALREADY, WHO IS DOING WHAT, WHAT ARE THE MEANS

6.1. AVAILABLE INTERNATIONAL EXISTING MEANS AND OPEX

The experience of WAGR demonstrated for a small size graphite reactor the feasibility of remote operation for the dismantling operations. The rates obtained for this small reactor, however, were low, performance needs to be significantly improved for UNGG reactors through risk mitigation and the industrial strategy to be retained. Depending on the nature of the graphite, the layout of the structures, the activation history, the benchmark is not directly transferable for the dismantling of graphite pile. Many different cases are to be considered in the framework of risk mitigation.

The demonstrator project took also into account Fort St Vrain and WAGR, nevertheless those decommissioning experiences were managed more than 20 years ago preventing nowadays operators from using the same methodologies and technics according to evolution of regulations and technologies.

6.2. INTERNATIONAL EXISTING COLLABORATION

In the Research fields, some international projects contain work packages about Graphite treatment: PFNeeds, BioProta, Cast...

In the Graphite industrial fields, a few international collaboration already exist, it is the case for example of the **Grapa** project :

- WP1 : Graphite characterisation
- WP2 : Graphite removal
- WP3 : Graphite Treatment
- WP5 : Graphite package and disposal

This project is more likely about graphite treatment but does not include collaboration about technologic development, tooling performance, operators safety, those gap have to be filled by a necessary element in the chain that is the demonstrator project. The Demonstrator project is a breakthrough in the field of technologic development because it enables partnerships among the technical but also regulatory and financing.

6.3. ALREADY AVAILABLE DATA AND PRESENT STATUS OF THE DEMONSTRATOR PROJECT

Reactor Dismantling Studies including the major risk assessment have already been implemented.

In the case of graphite reactor dismantling, usual adopted scenario main phases whatever is the country are the following :

- ✓ Upper concrete slab removal and new containment,
- ✓ Dismantling remote handling tools installation on the top of the reactor

- ✓ Dismantling operations
 - ✓ Upper Metallic structures (internals)
 - ✓ Graphite layers of bricks
 - ✓ Lower Metallic structures (core support)

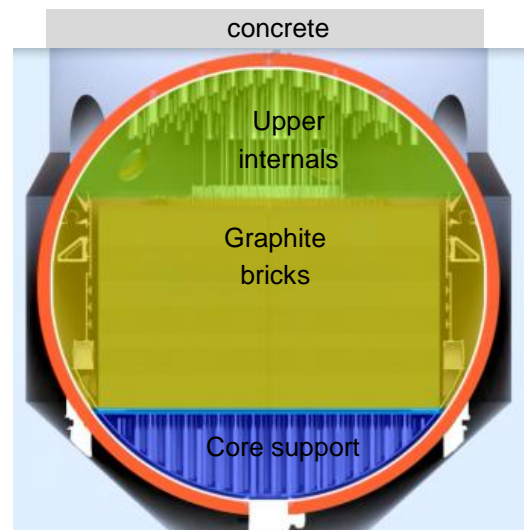

The global dismantling duration takes about 25 years

- ✓ Including tools installation,
- ✓ Based on average pace of cutting tools
- ✓ Including a preparatory phase prior to dismantling work of about 5 to 7 years

At this stage of the project the duration estimation is based on a flux study taking into account a detailed dismantling plan of each structure, rates of the tools and performance of the waste route.

Considering the great amount of operation due to the complexity and the geometry (260 000 graphite keys...) of this kind of reactor, the duration obtained is 25 years. This duration can be underestimated considering the main hazards related to the design of graphite gas reactors: Concrete (reactor opening and biological protection), metallic structures, and graphite bricks extraction

One of the main objectives of the demonstrator project is to mitigate the risks and optimize the schedule by developing the most efficient technology.

As described earlier, the demonstration project facility is being designed in order to demonstrate and optimize the dismantlement scenarios of EDF graphite reactors, starting with Chinon A2.

The aim of this testing facility is to test and optimize different known and innovative remote dismantling technologies up to the management of radioactive waste, physical tests being associated to digital models.

The Basic design of the demonstrator facility has been carried out. The conclusions led to a design including:

- An experimental hall enabling the settlement of a physical simulator with mock-ups. Global basic dimensions are 70m long, 35m wide, 20m high
- A modular conception in order to anticipate extensions (allowing future cooperations)
- Lifting means equipping the experimental hall such as a 40t crane system at first step,
- A back office platform designed for 20 persons (offices, digital room, services ...) at first step.

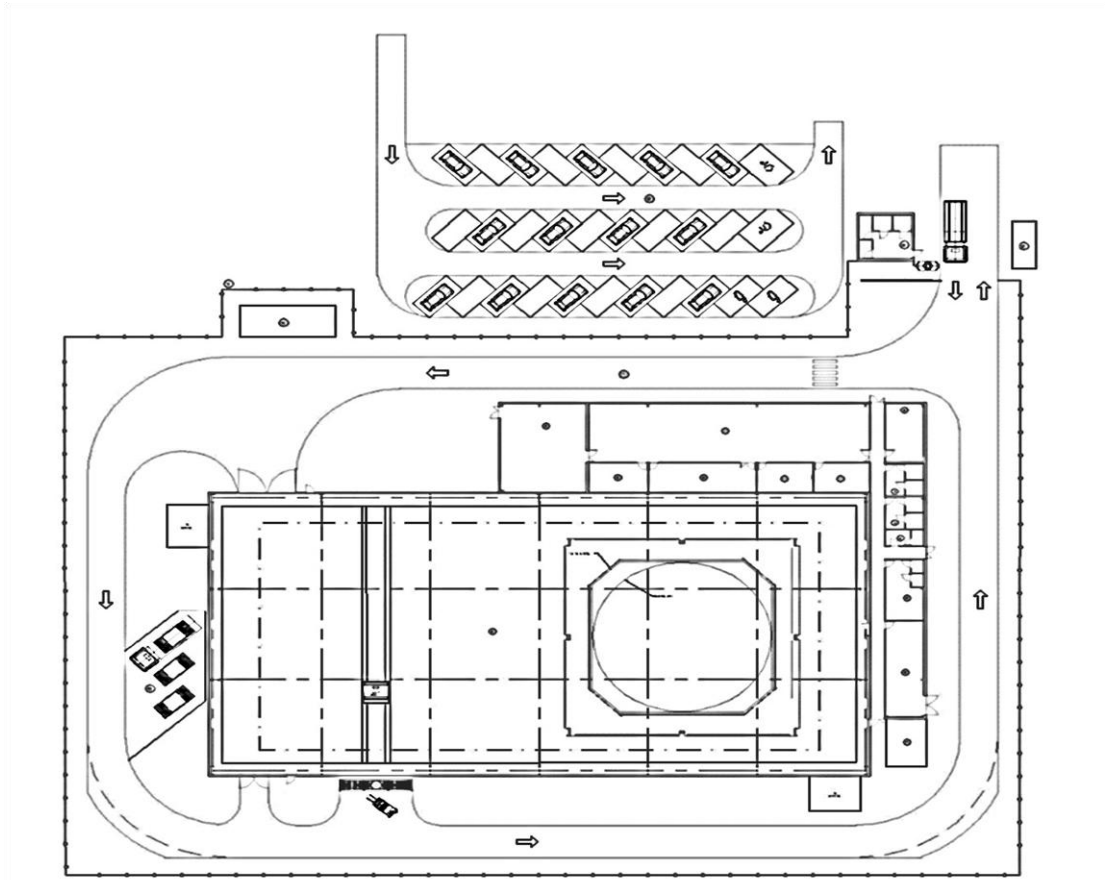

The final decision for the facility siting, nearby Chinon NPP is foreseen in early 2018.

Further detailed design activities, geological investigation and environmental impact studies will be conducted up to mid 2019. Building Permit is foreseen in September 2019. This milestone enables further development or improvements as needed if innovative purposes or future requirements (newcomers) occur.

The facility construction is supposed to be delivered in 2021.

A major milestone is the beginning of Testing activities in 2022.

The beginning of the Chinon A2 reactor dismantling is envisaged by 2032.

Nevertheless this demonstrator facility will remain available and operational after this date and it will be the opportunity to be used for further technologies or needs.

6.4. MORE RECENT INTERNATIONAL EXCHANGES

An international workshop was held in October 2017, the following subjects concerning Graphite reactor dismantling has been identified as “to be improved” with an international cooperation :

- Regulatory
- Dismantling scenario
- Waste management and characterization
- 3D simulation
- Representative characterization
- Graphite
- Inventory
- People
- Supply Chain

A number of attendees have already notified their respective interest to be actively involved in the realization of the demonstrator project : CEA (France), NDA (UK), Environmental Agency (UK), MAGNOX (UK), ENRESA (Spain),..

7. WHAT CAN BE DONE TO IMPROVE/ACCELERATE, IA THROUGH COOPERATION

7.1. INTERNATIONAL COOPERATION

The Chinon Site is very central considering potential partnerships with country potentially concerned (UK, Italy, Spain,...). Landfield for this project has been preempted following needs of further extensions.

Testing in the same place for different projects can :

- Optimize the development of common technologies, that can be use more than one time (financial gains on all projects)
- Share knowledge on common topics (asbestos, graphite, characterization, 3D simulation..)
- Take into account the different regulations in specific developments
- Help to convince safety authorities and stakeholders
- Optimize nuclear safety and waste management
- Structure international supply chain

The facility is designed in order to be modular and that extensions are possible for collaborations. The base workshop contains The Chinon A2 simulators. Additional simulators can be installed as far as the building is extended, the time program coordination of the international collaboration projects will help to reduce the extensions and costs. The same crane device can be used for all the simulators.

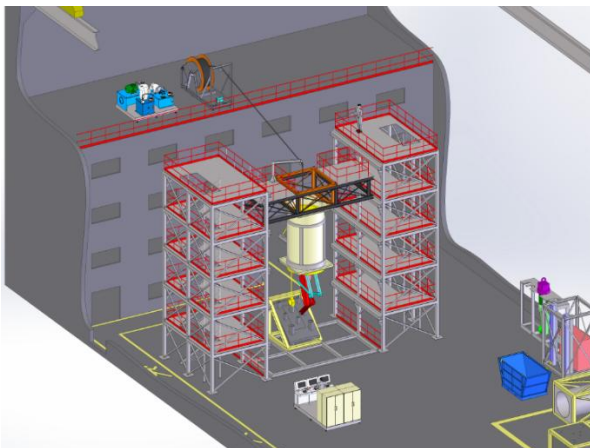

Basic simulator

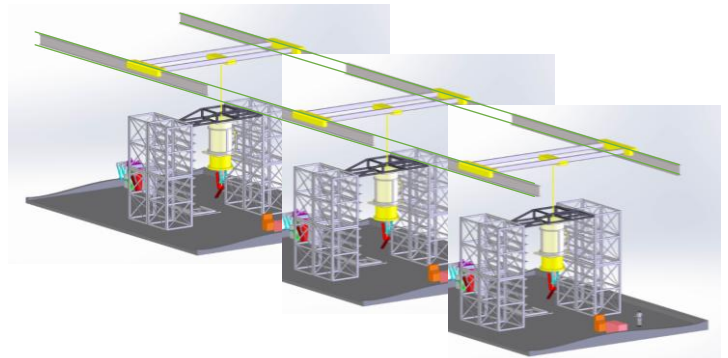

Additional simulators

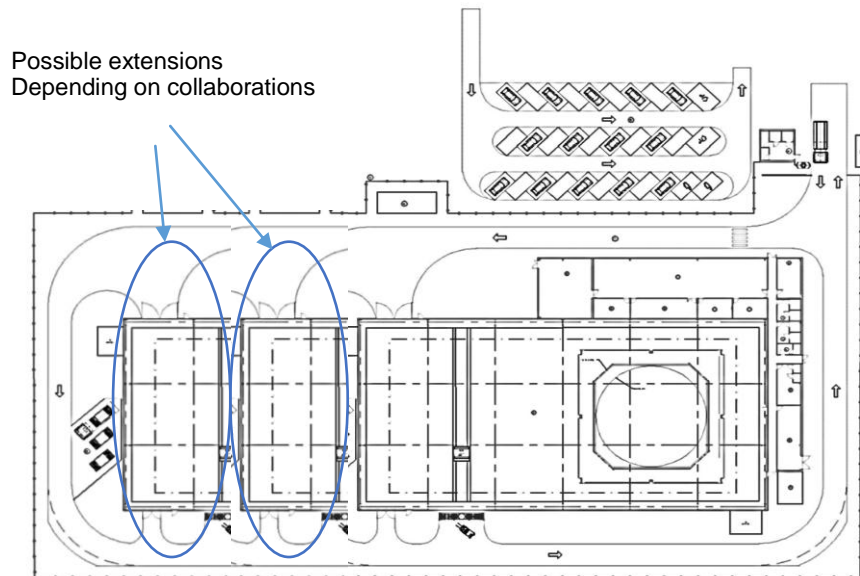

If international collaborations take place, it is envisaged to design also additional services (offices,...), it is also still acceptable if the decision is taken before early to change the capacity of the crane (100t for example) in order to take into account the characteristics of other technologies.

New potential enhancements (including other types of nuclear technologies decommissioning) can be foreseen and implemented as soon as global commitment with new stakeholders are envisaged.

7.2. PARTNERSHIPS

According to the international workshop held in October 2017, a number of attendees have already notified their respective interest to be actively involved in the realization of the demonstrator project : CEA (France), NDA (UK), Environmental Agency (UK), MAGNOX (UK), ENRESA (Spain),..

In addition, last January 2018, an agreement between both UK and French governments included a cooperation concerning this project.

Due to Chinon A2 characteristics, another number of potential partners may be interested in collaborating and involving themselves in this project thanks to similarity of their own facilities to be decommissioned: SOGIN (Latina), JAPC (Tokai Mura 1), Russians...

As the first motivation of this project is to assess graphite reactor dismantling during at least the first 10 years of operation, potential other graphite nuclear operators may be interested in being involved in such a project.

8. ACTION PLAN AND NECESSARY MEANS

A first basic design of the demonstrator has been completed in 2017 allowing to define a general schedule and a global budget.

The Schedule is driven by the Chinon A2 decommissioning operations starting in 2032. All the tests and simulation tools should be operational at that time.

The overall schedule is structured around the following milestones :

- 2018 : Demonstrator buiding Project creation
- 2021 : End of Mock-up installation and development of numerical tools
- 2023 ; End of elementary tests on concrete, metal and graphite
- 2026 : Qualification of processes, tools and numerical simulation
- 2032 : Beginning of reactor decommissioning with qualified tools/processes

During the reactor decommissioning of Chinon A2, the industrial demonstration will still be operational in order to keep development of tools and numerical simulation from operational feedback.

Overall schedule for industrial Demonstrator Project

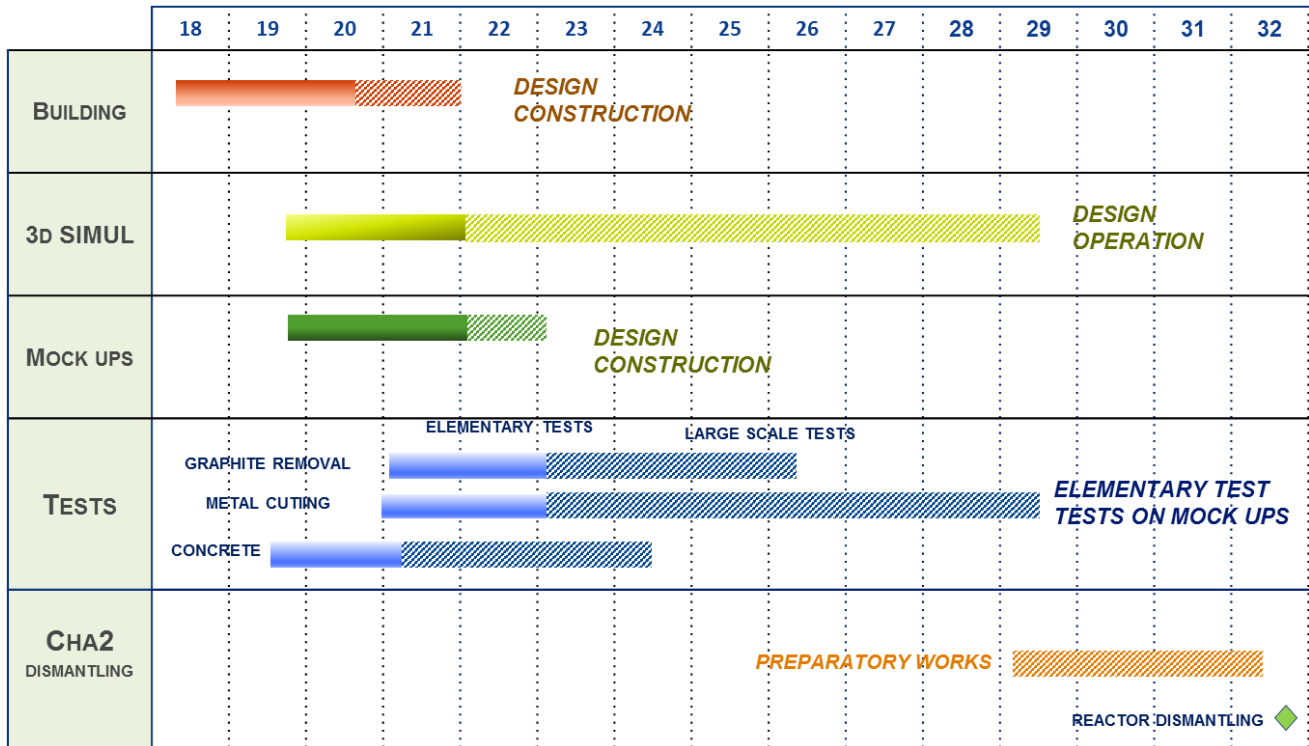

The preliminary assessment of the global budget of the industrial demonstrator is about 25M€. This cost includes the building construction (10M€) and the development and construction of mock-up with tools/processes and development of numerical simulators (5M€) and exploitation of the demonstrator (10M€ pour 10 years).

Engineering and R&D studies : 1M€

Demonstrator Building with mock-up :

- Building : 9 M€
- I&C (electricity, water supply, heat/air conditioning, fire protection....) : 1M€
- Inside equipment (crane, mock-up) : 3,5M€
- Logistics (meeting room, simulation rooms, offices) : 500k€

Demonstrator Operation Costs : 10M€

Starting in 2018, the operational phase of the industrial demonstrator will be engaged with the creation of a dedicated project. The following organization with the related items is presented hereafter.

Project's Organization and Main issues dedicated to the industrial Demonstrator

