

Resolving Complex Safety Relevant Issues Related to Hydrogen Release in Nuclear Power Plant Containments During a Postulated Severe Accident

A Summary Report by the
Hydrogen Mitigation Experiments
for Reactor Safety (HYMERES)
Project on the PANDA and
MISTRA Experiments

Unclassified

English text only

23 November 2018

**NUCLEAR ENERGY AGENCY
COMMITTEE ON THE SAFETY OF NUCLEAR INSTALLATIONS**

Resolving Complex Safety Relevant Issues Related to Hydrogen Release in Nuclear Power Plant Containments During a Postulated Severe Accident

A Summary Report by the Hydrogen Mitigation Experiments for Reactor Safety (HYMERES) Project on the PANDA and MISTRA Experiments

Please note that this document is available in pdf format only.

JT03440302

ORGANISATION FOR ECONOMIC CO-OPERATION AND DEVELOPMENT

The OECD is a unique forum where the governments of 36 democracies work together to address the economic, social and environmental challenges of globalisation. The OECD is also at the forefront of efforts to understand and to help governments respond to new developments and concerns, such as corporate governance, the information economy and the challenges of an ageing population. The Organisation provides a setting where governments can compare policy experiences, seek answers to common problems, identify good practice and work to co-ordinate domestic and international policies.

The OECD member countries are: Australia, Austria, Belgium, Canada, Chile, the Czech Republic, Denmark, Estonia, Finland, France, Germany, Greece, Hungary, Iceland, Ireland, Israel, Italy, Japan, Latvia, Lithuania, Luxembourg, Mexico, the Netherlands, New Zealand, Norway, Poland, Portugal, Korea, the Slovak Republic, Slovenia, Spain, Sweden, Switzerland, Turkey, the United Kingdom and the United States. The European Commission takes part in the work of the OECD.

OECD Publishing disseminates widely the results of the Organisation's statistics gathering and research on economic, social and environmental issues, as well as the conventions, guidelines and standards agreed by its members.

NUCLEAR ENERGY AGENCY

The OECD Nuclear Energy Agency (NEA) was established on 1 February 1958. Current NEA membership consists of 33 countries: Argentina, Australia, Austria, Belgium, Canada, the Czech Republic, Denmark, Finland, France, Germany, Greece, Hungary, Iceland, Ireland, Italy, Japan, Luxembourg, Mexico, the Netherlands, Norway, Poland, Portugal, Korea, Romania, Russia, the Slovak Republic, Slovenia, Spain, Sweden, Switzerland, Turkey, the United Kingdom and the United States. The European Commission and the International Atomic Energy Agency also take part in the work of the Agency.

The mission of the NEA is:

- to assist its member countries in maintaining and further developing, through international co-operation, the scientific, technological and legal bases required for a safe, environmentally sound and economical use of nuclear energy for peaceful purposes;
- to provide authoritative assessments and to forge common understandings on key issues as input to government decisions on nuclear energy policy and to broader OECD analyses in areas such as energy and the sustainable development of low-carbon economies.

Specific areas of competence of the NEA include the safety and regulation of nuclear activities, radioactive waste management and decommissioning, radiological protection, nuclear science, economic and technical analyses of the nuclear fuel cycle, nuclear law and liability, and public information. The NEA Data Bank provides nuclear data and computer program services for participating countries.

This document, as well as any [statistical] data and map included herein, are without prejudice to the status of or sovereignty over any territory, to the delimitation of international frontiers and boundaries and to the name of any territory, city or area.

Corrigenda to OECD publications may be found online at: www.oecd.org/publishing/corrigenda.

© OECD 2018

You can copy, download or print OECD content for your own use, and you can include excerpts from OECD publications, databases and multimedia products in your own documents, presentations, blogs, websites and teaching materials, provided that suitable acknowledgement of the OECD as source and copyright owner is given. All requests for public or commercial use and translation rights should be submitted to neapub@oecd-nea.org. Requests for permission to photocopy portions of this material for public or commercial use shall be addressed directly to the Copyright Clearance Center (CCC) at info@copyright.com or the Centre français d'exploitation du droit de copie (CFC) contact@cfcopies.com.

Committee on the Safety of Nuclear Installations

The Committee on the Safety of Nuclear Installations (CSNI) is responsible for the Nuclear Energy Agency (NEA) programmes and activities that support maintaining and advancing the scientific and technical knowledge base of the safety of nuclear installations.

The Committee constitutes a forum for the exchange of technical information and for collaboration between organisations, which can contribute, from their respective backgrounds in research, development and engineering, to its activities. It has regard to the exchange of information between member countries and safety R&D programmes of various sizes in order to keep all member countries involved in and abreast of developments in technical safety matters.

The Committee reviews the state of knowledge on important topics of nuclear safety science and techniques and of safety assessments, and ensures that operating experience is appropriately accounted for in its activities. It initiates and conducts programmes identified by these reviews and assessments in order to confirm safety, overcome discrepancies, develop improvements and reach consensus on technical issues of common interest. It promotes the co-ordination of work in different member countries that serve to maintain and enhance competence in nuclear safety matters, including the establishment of joint undertakings (e.g. joint research and data projects), and assists in the feedback of the results to participating organisations. The Committee ensures that valuable end-products of the technical reviews and analyses are provided to members in a timely manner, and made publicly available when appropriate, to support broader nuclear safety.

The Committee focuses primarily on the safety aspects of existing power reactors, other nuclear installations and new power reactors; it also considers the safety implications of scientific and technical developments of future reactor technologies and designs. Further, the scope for the Committee includes human and organisational research activities and technical developments that affect nuclear safety

Foreword

The Hydrogen Mitigation Experiments for Reactor Safety (HYMERES) Project, hereafter identified as “the Project”, is an international joint project under the auspices of the Nuclear Energy Agency (NEA), with support provided by 13 countries: Canada, China, the Czech Republic, Finland, France, Germany, India, Japan, Korea, the Russian Federation, Spain, Sweden and Switzerland. The Paul Scherrer Institute (PSI, Switzerland) and the Commissariat à l'énergie atomique et aux énergies alternatives (CEA, France) acted as operating agents.

Phase 1 of the Project, between 2013 and 2016, focused on improving the physical understanding of hydrogen release, transport and mixing in nuclear reactor containments and studying suppression pressure pool system issues with the goal of enhancing the modelling capabilities in support of safety assessments that will be performed for current and new nuclear power plants.

Hydrogen is an important concern because deflagration and even detonation can occur, which might result in a damage of the containment with a possible release of radioactive material into the environment. Thus it is crucial to know 1) how the hydrogen mixes with air and steam, 2) if this mixing would lead to a uniform distribution of hydrogen or, in contrast, 3) if the hydrogen would accumulate in specific regions.

The complexity of a severe accident progression allows a rigorous analysis only by using advanced lumped-parameter (LP) and computational tools with 3D capabilities. However, the reliability of these computational tools requires extensive assessment and validation activities by comparing the code results with experimental data relevant to phenomena occurring during the accident. The lack of adequate experimental data representing the broad range of phenomena and scenarios occurring in various LWR, ALWR and HWR containments during postulated accident conditions is one of the hindrances in the assessment and validation of computational tools. Furthermore, these data should be preferentially obtained in large-scale, multi-compartment facilities to minimise possible distortional effects resulting from scaling issues. These experiments require, especially when 3D effects characterise the phenomena, a high resolution instrumentation, which poses another challenge for experimental programmes addressing issues that have a high relevance for nuclear safety. Previous experimental programmes addressed mostly basic flows and configurations, suitable for the basis of a comprehensive database for the evaluation of the codes. However, the validation of the codes also requires experimental data for the more complex situations that can be anticipated to prevail in a real plant under accident conditions. Consequently, the Project addressed new elements in the experiments in order to provide the members with unique high quality data for code validation purposes.

The present project summary report was prepared in order to provide the international research community with an overview of the main outcomes of Phase 1 of the Project. It was submitted to the NEA Committee on the Safety of Nuclear Installations (CSNI) and to the Project participants.

The experimental data and the Project deliverables produced during the Project were distributed to the Project signatories. The Management Board of the Project has agreed that these data and the final Project report of this Phase can also be released to non-signatory NEA member countries after the confidentiality period has expired.

Table of contents

| | |
|--|-----------|
| List of abbreviations and acronyms..... | 7 |
| Executive summary | 8 |
| Project outcome | 11 |
| Background..... | 11 |
| Objective of the work | 12 |
| Work performed..... | 13 |
| Results and their significance | 16 |
| 2. Conclusions and recommendations..... | 24 |

List of table and figures

| | |
|---|----|
| Table 1: PANDA and MISTRA test series | 9 |
| Figure 1.1. 3D view of the four PANDA vessels with connection pipes for the HP6 series addressing complex natural circulation in two-room type containment. | 14 |
| Figure 1.2. MISTRA facility | 15 |

List of abbreviations and acroynms

| | |
|---------|---|
| ALWR | Advanced light water reactor |
| BWR | Boiling water reactor |
| CEA | Commissariat à l'énergie atomique et aux énergies alternatives (France) |
| CFD | Computational fluid dynamics |
| EPR | European pressurised reactor |
| ERCOSAM | European project: Containment thermal-hydraulics of current and future light water reactors for severe accident management |
| GDCS | Gravity driven cooling system |
| GOTHIC | Thermal-hydraulics software package |
| HWR | Heavy water reactor |
| IP | Injection pipe |
| JAEA | Japan Atomic Energy Agency |
| KONVOI | Reactor line designed by Siemens/KWU |
| LWR | Light water reactor |
| MAKET | Separate effect test facility representing half of the upper part of the MISTRA facility |
| MISTRA | Experimental facility used to study hydrogen risks at the Commissariat à l'énergie atomique et aux énergies alternatives (Mitigation et stratification) |
| OA | Operating agent |
| PANDA | Large-scale, thermal-hydraulics test facility at the Paul Scherrer Institute |
| PARIS | Research project on radiolytic oxidation of molecular iodine in containment during a nuclear reactor severe accident |
| PHWR | Pressurised heavy water reactor |
| PIV | Particle image velocimetry |
| PSI | Paul Scherrer Institute (Switzerland) |
| PWR | Pressurised water reactor |
| RPV | Reactor pressure vessel |
| SARNET | Severe Accident Research Network of Excellence |
| THAI | NEA Thermal-hydraulics, Hydrogen, Aerosols and Iodine Project (international joint project) |

Executive summary

Hydrogen generated during a postulated severe accident with core degradation is a major safety issue because explosive gas mixtures could form in the containment and threaten the containment integrity.

Phase 1 of the NEA Hydrogen Mitigation Experiments for Reactor Safety (HYMERES) Project was carried out during the period 2013-2016 with experimental investigations in the PANDA and MISTRA facilities to further advance knowledge on hydrogen distribution in nuclear reactor containments. Moreover, one of the PANDA series of the HYMERES Project was devoted to suppression pool system issues. Three major topics have been investigated during this phase of the Project:

1. Realistic flow conditions were addressed (e.g. diffused flow resulting from a jet impinging onto walls or inner partitions), providing information for the evaluation of basic computational and modelling requirements (mesh size, turbulent models, etc.) needed to analyse a real nuclear power plant.
2. Experiments addressing the interaction of safety components were performed. Different combinations of “safety elements” were studied, e.g. the thermal effects created by one and two passive autocatalytic re-combiners, spray and cooler, spray and opening hatches. Some of these elements were operated simultaneously.
3. The system behaviour for selected accident scenarios was addressed. In certain reactor types (e.g. various BWR, PWR or PHWRs designs), the hydrogen concentration evolution in the containment depends on the responses of different components in the system.

The PANDA and MISTRA series performed within Phase 1 of the NEA HYMERES Project are summarised in Table 1. The total number of tests indicated in the last line of Table 1 includes the tests specified respectively for PANDA and for MISTRA. Additional tests were necessary (and are not indicated in Table 1) to identify an optimal test procedure, experiments to verify the repeatability and tests to clarify additional thermal-hydraulic phenomena that are linked to the individual series.

Table 1: PANDA and MISTRA test series

| | PANDA | MISTRA |
|--|--------------|---------------|
| Separate effects/flow obstructions | | |
| Jet/plume interacting with flow obstruction | HP1 | HM1 |
| Safety components/systems | | |
| Heat source with flow obstruction | HP2 | HM2 |
| Two heat sources with flow obstruction | HP3 | HM3 |
| Spray and cooler | HP4 | |
| Thermal stratification build-up and homogenisation in a water pool | HP5 | |
| Natural circulation flow induced by opening hatches and effect on safety systems | HP6 | |
| Total number of tests | 24 | 9 |

For the topics “separate effects/flow obstructions”, the series HP1 and HM1 addressing jet/plume interacting with flow obstructions and then eroding a stratified helium layer (as proxy for hydrogen) were performed in the PANDA and MISTRA facilities. The flow obstruction for the jet consists in a horizontal circular disc or vertical rectangular plate (PANDA) while the vertical cylindrical inner compartment was used for the MISTRA tests.

For the topic “safety components/systems” the series HP2-HP3 and HM2-HM3 addressing the effect of one and two heat sources, and a jet interacting with a flow obstruction onto the hydrogen distribution, were performed in the PANDA and MISTRA facilities.

The same heater elements were used in PANDA for the series HP2-HP3 and in MISTRA for HM2-HM3. The heater elements were manufactured by CEA and were used first for the MISTRA series and were later shipped to PSI and used for the PANDA series.

The series “spray and cooler”, “thermal stratification build-up and homogenisation in a water pool” and “natural circulation flow induced by opening hatches and effect on safety systems” were performed in PANDA. These tests addressed issues related to the activation of safety components in PWR (HP4), thermal evolution in the suppression pool of BWR under venting conditions from a sparger (HP5), and complex natural circulation in the so-called two-room containment of PWR (e.g. KONVOI and EPRTM type) and HWR (HP6).

An effort has been made by the operating agents during the Project to optimise the location of facility instrumentation as a function of the specific test series and considering the needs for code validation. The Project has generated a unique experimental database for code validation purposes. The Project participants have contributed with analytical activities carried out with different codes to define (scoping calculations) and to analyse (pre and/or post- test analyses) the tests. Two blind benchmarks of code analyses based on one PANDA and one MISTRA test were carried out during Phase 1 of the NEA HYMERES project. Five analytical workshops were organised before the Programme Review Group Meetings (PRG3 to PRG8).

The Project investigations have high safety relevance and contribute to increasing the knowledge of hydrogen transport, mixing and stratification break-up induced by mass sources and by the activation of system components such as containment sprays, coolers or heat sources simulating re-combiners. Moreover, the tests related to thermal evolution in a water pool under various venting conditions, including steam/hydrogen venting and the tests addressing complex natural circulation in two-room containment, have been defined considering specific features of some existing LWRs and HWRs. The analysis of the experiments with various computational tools, carried out by the Project participants during Phase 1 of the Project, allows a thorough evaluation of code capabilities and contribute to identifying areas where additional investigations are needed (e.g. modelling of containment internal structures, effects of radiative heat transfer, remaining issues in pools and safety components). Based on the identified needs, the operating agents proposed to continue the HYMERES Project with a Phase 2.

In order to enhance the reliability of the code predictions and to minimise the so-called “user effect”, it is of paramount importance to have a continuous validation of the computational tools. For those phenomena for which a certain maturity in the modelling has been reached, it is recommended to perform additional blind code benchmarks for assessing the computational tools predictive capabilities and the user effect in the framework of Phase 2 of the HYMERES Project.

The present summary report will provide a brief description of the PANDA and MISTRA facilities, the specific objectives for each individual series listed in Table 1 and the significant results.

Project outcome

Background

The containment of a nuclear power plant is the last barrier to prevent the release of any radiologically active material in the environment. As a consequence, plant safety systems must ensure containment integrity in all possible accident scenarios.

Hydrogen generated during a postulated severe accident with core degradation is a major safety issue because explosive gas mixtures could form in the containment.

During the accident at the Fukushima power plant, hydrogen explosions took place in the containment building of two reactor units. This has demonstrated on the one hand how complex the evolution of a severe accident can be and, on the other hand, the importance of establishing safety measures for the mitigation of the hydrogen risk. The hydrogen (and air) distribution is a key aspect in the hydrogen hazard because flammable or explosive mixtures could form in a region of the containment or containment building, which could threaten containment integrity or damage systems that have safety functions. Consequently, hydrogen mitigation measures, e.g. igniters, PARs, should be located in those containment regions where the code predictions indicate the formation of flammable mixtures.

The analysis of hydrogen distribution is very complex. One has to consider the hydrogen release and transport, the mixing of hydrogen with other gases or the build-up of stratification with steam, air or nitrogen, the condensation of steam and the re-evaporation of water, the radiative heat transfer as well as the effect of safety components. Moreover, various reactor types (BWRs, PWRs, HWRs, etc.) have a number of design specific differences which have to be properly accounted for in any analysis. Also several scenarios (e.g. fast release, long lasting station black-out, ex-Vessel scenarios) should be analysed, considering specific reactor type features.

Advanced LP and CFD codes are valuable tools to analyse the LWR, ALWR and HWR behaviour during (postulated) design and beyond-design-basis accidents. At present, the extent of code assessment and validation is one limiting factor in their application for reactor safety analyses. One of the hindrances is the lack of adequate experimental data with the required time and spatial resolution. Furthermore, the validation process itself is important to improve the “computational tool user experience” in analysing the phenomena in the containment to minimise what is sometimes called the “user effect”. For example, the recent NEA/Paul Scherrer Institute (PSI) blind benchmark based on a PANDA test for an already simplified containment scenario has demonstrated large discrepancies among the contributions even though some of the participants have used the same code.

To enhance the reliability of the code predictions, the technical community is committed to promoting a comprehensive validation of the computational tools used in containment safety analysis, as well as to provide opportunities for continuous training and an

exchange of experiences among those experts who are planning to use the computational tools for the analysis of real containment scenarios.

In the framework of various projects, the results obtained in the PANDA (PSI, Switzerland) and MISTRA (CEA, France) thermal-hydraulics facilities were extensively used in the last years by the research community. The HYMERES Project was carried out with experimental investigations in the PANDA and MISTRA facilities to further advance the knowledge on hydrogen distribution in nuclear reactor containments for more prototypical thermal-hydraulic conditions and suppression pools dynamics, thus extending the data base for code validation for a range of phenomena that have safety relevance. Moreover, one of the PANDA series was performed to investigate suppression pool system issues. The 13 countries that have participated and supported the Project are: Canada, China, the Czech Republic, Finland, France, Germany, India, Japan, Korea, the Russian Federation, Spain, Sweden and Switzerland.

Objective of the work

Phase 1 of the Project was carried out to improve the physical understanding of different thermal-hydraulic scenarios linked to the hydrogen risk in containments with a focus on hydrogen mixing and distribution in the presence of flow obstructions and safety components, as for example heaters and coolers, all of which modify the temperature, concentration and flow field. Throughout all the experiments in the PANDA and MISTRA facilities helium was used to simulate hydrogen.

Compared with previous projects related to hydrogen issues, the new project includes three new elements.

1. Realistic flow conditions were addressed. For example, a diffused flow that results from a jet impinging onto flow obstructions like inner partitions and walls. Thus the flow past the obstacle results from a combination of initial jet momentum dissipation and momentum re-distribution; a flow that might considerably challenge computational codes. For the experiments, these situations were realised with horizontal or vertical plates (PANDA) or cylindrical flow obstructions (MISTRA).
2. Experiments addressing the interaction of containment safety components were performed. Different combinations of containment safety elements, their influence on the flow field and the resulting helium distribution were investigated. For example, the combined effect of the activation of a cooler and a spray (PANDA), the effect of two heaters (PANDA and MISTRA) and steam venting in a water pool through a sparger, as well as water injection in the pool by a nozzle (PANDA) were studied.
3. Experiments that can be labelled as “containment system tests” were conducted to study complex natural circulation phenomena in the containment. These experiments in all four PANDA vessels considered the opening of rupture discs or mixing dampers.

The facility characteristics, the specific objectives for each individual PANDA and MISTRA series and the significant results are discussed in the following sections.

Work performed

PANDA is a large-scale (Figure 1), multi-compartment thermal-hydraulic facility consisting of six main vessels with a total volume of approximately 515 m³ and four condenser systems immersed in four water pools. The overall height of the facility is 25 m. The facility can be operated in the range of 0-10 bar and up to 200 °C. All the six vessels were used for the Project throughout the different series. For the series HP1, HP2, HP3 and HP4 Vessel 1 and Vessel 2 were used. For series HP5 Vessel 3 and for series HP6 Vessel 1, Vessel 2, Vessel 3 and Vessel 4 were used. The height of Vessel 1 and Vessel 2 is about 8 m and the diameter of each Vessel is 4 m. The height of Vessels 3 and 4 is about 10 m and the diameter also of about 4 m. The remaining two PANDA vessels, depicted as RPV and GDCS, were used as steam generator (RPV) or as water reservoir (GDCS).

MISTRA is a large-scale thermal-hydraulics facility (Figure 2) consisting of a main vessel with a free volume of 97.6 m³, an internal diameter of 4.25 m and a height of 7.38 m. The maximum operating conditions are six bars with a mean gas temperature of 150 °C (200 °C at the steam injection nozzle).

The PANDA and MISTRA series performed within the Project can be found in Table 1. Thirty three tests are specified in the Project agreement; twenty four tests in PANDA and nine tests in MISTRA. The total number of tests given in the last line of the Table 1 includes the tests specified in the Project. Additional tests were necessary (and are not indicated in Table 1) to identify an optimal test procedure, experiments to verify the repeatability and tests to clarify additional thermal-hydraulic phenomena.

Figure 1.1. 3D view of the four PANDA vessels with connection pipes for the HP6 series addressing complex natural circulation in two-room type containment.

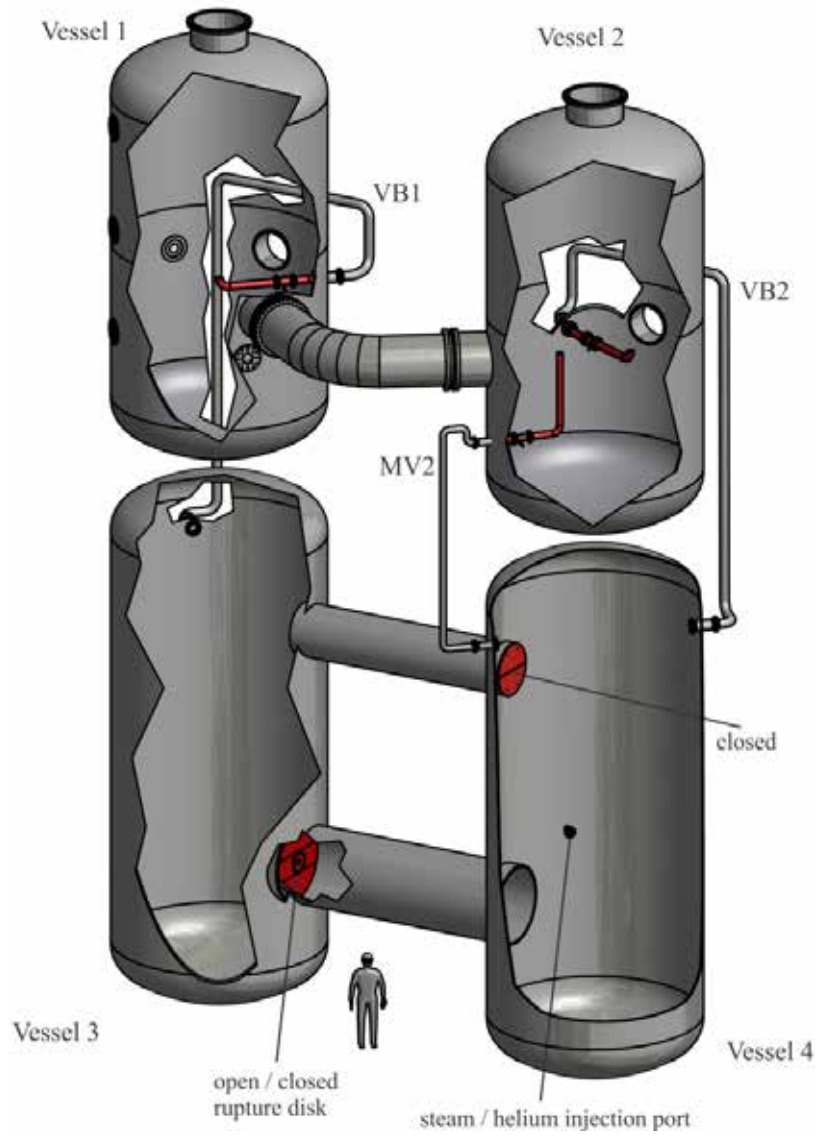
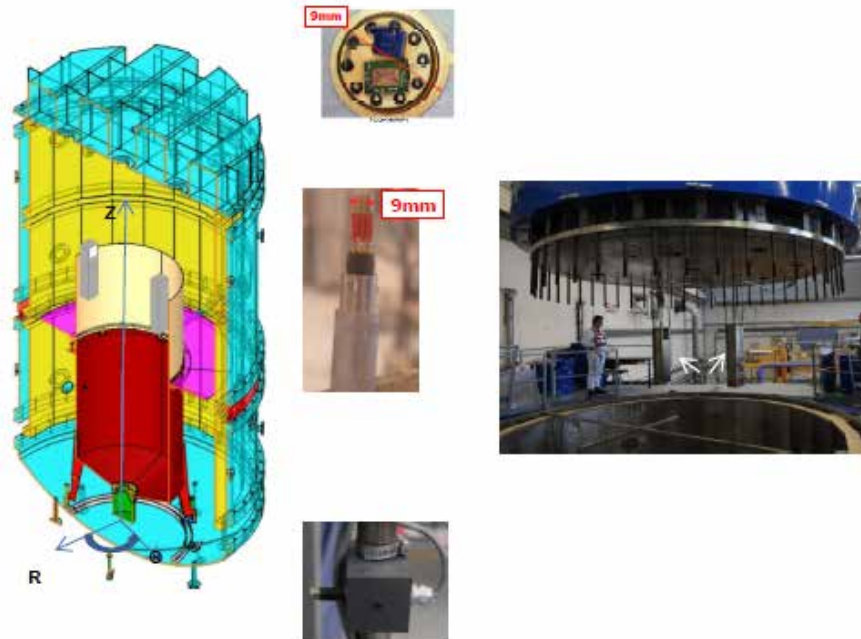

Figure 1.2. MISTRA facility

Overview of the geometry (left) – Mini-katharometer design (centre) –
two heaters fixed on the flat cap of the MISTRA facility (right)



For the topics “flow obstructions” (series HP1 and HM1) as well as for “heat sources” (HP2/3 and HM2/3), experiments were defined for both PANDA and MISTRA facilities. The flow obstruction for the jet consists in a horizontal circular disc or vertical rectangular plate (PANDA), while the vertical cylindrical inner compartment was used for the MISTRA tests. The same heater elements were used in PANDA for the series HP2/3 and in MISTRA for HM2/3. The heater elements were manufactured by CEA and were used first for the MISTRA series and were later shipped to PSI and used for the PANDA series.

PANDA facility modifications

The PANDA facility was used to conduct six experimental series (HP1 to HP6, Table 1). Each series required facility modifications. To mention just the most relevant adaptations, these modifications included:

- various flow obstructions and injection lines for the HP1 series;
- the heater elements and vertical condenser for the HP2/3 series;
- the spray nozzle and the cooler systems for the HP4 series;
- the sparger, nozzle systems and three new PIV windows for the HP5 series;
- the design and manufacturing of various tubes for the representation of the two-room containment for the HP6 series.

Additionally, these experiments required upgrading the control system and adapting for each series the number and the locations of the sensors for temperature and gas concentration measurements to obtain an optimal sensor grid resolution. For series HP5,

Vessel 3 was equipped with three windows to perform PIV and high speed recordings in the water pool. New seeding techniques were developed and implemented to measure flow velocities in a two phase flow environment (HP5) and for gas flows entering heaters with a 500 °C surface temperature (HP2/3).

MISTRA facility modifications

For the HM1 series, a new horizontal lateral injection line was built and connected either to an independent hot air injection system or to the main steam injection line coming from the MISTRA boiler. To position the additional instrumentation appropriately in order to monitor the lateral injection, a separate effect test facility was constructed: the MAKET experiment, representing half of the upper part of the MISTRA facility at full scale. In these tests, the steady-state flow pattern and the 3D temperature field during lateral injection of hot air were characterised. Finally, two thermal re-combiners manufactured for the ERCOSAM European Project were also used for the HM2 and HM3 series. These devices were loaned to PSI for the HP2 and HP3 series.

“CFD-grade” requirements results in a large number of measurement points to have a better understanding of the complex phenomena occurring during these tests. Consequently, a greater number of katharometers positioned on three vertical masts allowed the finer tracking of the mixing transient for air/helium mixtures during the three series. Developments and tests were also initiated to miniaturise and make these devices less intrusive. Moreover, measurements of velocity using hot wire probes were performed to characterise velocity profiles at the exit of the lateral injection pipe; data essential for the validation of the CFD models, and to obtain some velocity measurement points in the HM1-1 used for the comparison with the calculations performed in the benchmark exercise.

Analytical activities

The Project participants accompanied the test campaigns in PANDA and MISTRA with analytical activities performed with a variety of computational tools. The activities included scoping calculations to select the test conditions and the analysis of specific tests. Analytical workshops were conducted as an integral part during the last five Programme Review Group Meetings – even though not being an official part of the Project. Based on PANDA and MISTRA experiments, two successful blind benchmarks were carried out during the Project. The analytical activities performed so far have already proven the suitability of the data for the assessment and validation of advanced LP and CFD codes. Areas where further experimental investigations are needed were also identified.

Results and their significance

The experimental program carried out in the frame of the Project has high safety relevance for LWRs/ALWRs/HWRs. It contributes in particular to expand the knowledge on thermal-hydraulic phenomena related to the hydrogen mixing and distribution in the containment during postulated accident scenarios as well as on the thermal evolution in a water pool under various venting conditions including steam/hydrogen venting.

PANDA

HP series: Jet/plume interacting with flow obstruction

The HP1 series consisted in eight tests addressing the erosion of a helium-rich layer by i) a vertical jet interacting with a horizontal flow obstruction (a circular disc) and ii) a horizontal jet interacting with a vertical flow obstruction (a rectangular plate). Parameters for these experiments were the distance between the horizontal jet orifice and the vertical rectangular plate, the jet buoyancy, the jet momentum, condensing vs. non-condensing environment and vented (constant pressure) versus non-vented (pressure increase) conditions.

The tests with vertical flow obstruction showed that a small change in the geometry might result in a large change in the flow pattern. Shortening the distance between the horizontal jet and the vertical plate slowed down the helium erosion process by a factor of about two. Furthermore, increasing the initial jet buoyancy and the pressurisation of the vessels accelerated the helium layer erosion process. The tests with horizontal flow obstruction showed that decreasing the jet Reynolds number by a factor of two tripled the helium layer erosion time. On the other hand, changing the initial jet buoyancy does not have a dramatic effect on the overall helium layer erosion time. The tests also showed a peculiar flow pattern resulting from the interaction between the vertical jet and a horizontal disc. The resulting jet diameter past the disc becomes considerably smaller compared to an un-blocked jet which would spread continuously until it interacts with the helium-rich stratification. There are two competing effects important for the erosion time. The reduction of the jet momentum through the interaction with the disc decreases the initial penetration depth into the helium stratification and the jet re-confinement past the disc which concentrates the available momentum into a smaller area results in a higher initial penetration depth.

Analytical benchmark within the HP1 series

One of the experiments of the HP1 series in PANDA (HP1_6_2) was chosen for a blind benchmark. It addressed the stratification erosion in Vessel 1 of an initially helium-rich layer on top of pure steam induced by a vertical steam jet in the presence of an obstruction 1 m above the jet source (pipe exit). In order to enhance the interpretation of the comparison of the calculated results with the experimental data, the participants were requested to submit two sets of results: one set should be obtained using a “common model” (CM), and a second set produced by a “best estimate” model (BEM). For the CM, a list of recommendations was given with respect to initial and boundary conditions (e.g.: homogeneous initial vertical gas and wall temperatures, modelling of the injection pipe), as well as concerning model selection (no condensation, no radiative heat transfer, standard k- ϵ turbulence model). For the BEM, each participant was free to choose the modelling approach that was considered to be the best suited to the physical problem investigated, also on the base of previous experience, and to use refined representation of initial and boundary conditions. Each participant was expected to submit only one set of results for each of the two models. The participants were encouraged to use Best Practice Guidelines (BPG) to provide the most trustworthy set of results, but only few participants could afford more than a mesh sensitivity study using two meshes.

Thirteen organisations from 11 countries contributed to the CM results, whereas 11 organisations submitted results using the BEM. Both sets of simulations produced a large variety of results. The large differences in the results with the CM were, in

particular, not expected because a comprehensive set of specifications was recommended. It turned out that this approach was not sufficient to reduce the spread of the results. The specifications covered various aspects of the simulation (geometry, turbulence modelling, initial, and boundary conditions, some fluid and flow properties, etc.), but not all (e.g. wall treatment), and therefore some of the differences could be due to specific code inputs as well as to the numerical methods used. Moreover, since the level of validation (including mesh convergence studies and application of BPG) was different for the various contributions, it is difficult to draw any conclusions from the comparison of the requested results. It can only be observed that, similarly to previous exercises for similar flows and configurations (but without obstruction, i.e. CFD4NRS PANDA benchmark), the present results suggest that whenever a new problem is tackled, established modelling strategies must be evaluated again. The outcome of the exercise reinforced the awareness of the spread of results that can be obtained if the adequacy of the mesh is solely evaluated on the base of previous experience and limited mesh refinement studies.

The results obtained by each participant using the best estimate model show that the combination of mesh and modelling approach again can result in a wide spread of results, with the quality of the results not always being improved using a model selection that proved to be successful for other configurations and test conditions.

The comparison between predicted and experimental results, as well as between simulations, raised a few questions about the actual importance of considering radiative heat transfer, the relation between mesh topology and other modelling aspects (turbulence model, numerical methods, boundary conditions, etc.), and the effect of some test conditions that were not modelled (e.g. non-symmetry of the flow at the outlet of the pipe).

To help to resolve these questions, an open phase of the benchmark was started, where extended data from auxiliary tests (the HP1-X-0 tests, conducted for similar conditions to those of HP1_6_2, but without helium layer) are provided to the participants to permit a more basic validation of their models, by comparing the results for the flow downstream of the obstruction, which, in turn, are affected by the accuracy in simulating the free jet below the obstruction. The exercise was divided in several steps, with only five organisations providing results for the final step, i.e. for the post-test analysis of the full-problem (HP1_6_2), with improved models. The open benchmark is currently being finalised, and the conclusions will be provided in a dedicated report.

HP2/HP3 series: Heat source(s) with flow obstruction

The HP2/3 series were performed to study the influence of one or two heat sources (representing PARs) on the erosion of a stratified gas atmosphere by a vertical steam jet in the presence of an obstruction 1 m above the jet source (pipe exit) with containment wall condensation. The helium-rich layer was not created prior to the experiments but resulted from the steam and steam/helium jet in conjunction with the condensation. The heater elements used are identical with those used first in MISTRA for the HM2/3 series. The heater elements were installed in the PANDA Vessel 1 at a given radial location and two different elevations, one above and one below the level of steam/helium injection. A condenser consisting of three vertical tubes of about 6 m length installed close to the Vessel wall was designed to represent the condensation which would take place during the postulated scenarios at the concrete wall of a real containment. The condensation at the concrete wall induces convection and contributes to a certain extent to the overall helium distribution and might enhance the mixing of the gases caused by the plumes

rising from the heat sources. During the HP2 series either the bottom or the top heater was activated and during a zero-test none of the heaters were activated to study the convection induced by the cooler. During the HP3 series both heaters were activated. The experimental conditions were defined based on preliminary scoping calculations with GOTHIC. Since the heaters represent PARs they were activated and the power for the bottom heater was subsequently continuously increased once the helium concentration at the heater inlet reached about 1 %. The power ascent and descent of the heaters were determined from the scoping calculations.

The activation of only the upper heater created a homogenous gas mixture *above* the level of the heater, while forming a sharp concentration gradient below it. By operating only the lower heater, the emerging plume homogenised the *entire* Vessel 1 at the end of the test, showing that it was more effective in mixing the gas, albeit having lower heater power and a shorter operation time. The simultaneous activation of the upper and the lower heaters accelerated the break-up of the helium stratification formed above the jet injection level, while also homogenising the entire Vessel 1 at the end of the test. The PIV measurements revealed the flow field below the upper heater, at the exit of the injection pipe and around the flow obstruction plate. The strong *inclined* plume created by the lower heater and the horizontal flow eventually induced by the cooler operation measured with PIV are the characteristic features that could be the focus of the detailed analysis with computational codes.

HP4 series: Spray and cooler

The HP4 series was conducted to investigate the combined effect of spray and cooler activation on the distribution of the containment atmosphere in the presence of a vertical jet impinging onto a cooler.

The test configuration consisted of a vertical pipe, with its exit in the lower region of Vessel 1 (below the IP) from which the jet emerged, a cooler, centred 1.9 m above the injection exit and a spray nozzle directed downward in the centre of the upper region of the Vessel. As for the HP2/3 series, the gas mixture stratification was not created as initial condition but resulted from the test scenario that consisted of five phases. Steam release and cooler activation were initiated in Phase 1 and lasted the full duration of the tests. Helium was additionally released in Phase 2 and the spray was activated in Phases 3 and 5 with the same water mass flow rate. Four tests were performed to address the effect of the spray water temperature, the spray design (full cone or hollow cone nozzle), and the cooler geometry on the overall gas transport and concentration. One additional test was performed without the activation of spray, to isolate the effect of cooler from the spray.

In the second phase of the experiment, a strong steam/helium stratification built-up was monitored between the upper part (high concentration) and lower parts (low concentration) of the vessels. In Phase 3 a homogeneous mixing was obtained in Vessel 1 where the spray was activated while a stratified atmosphere remained in the adjacent Vessel. The effect of the spray design (full cone/hollow cone) on the final concentration distribution was minimal despite large differences in the droplet velocity profile between the full cone and the hollow cone nozzles. In Phase 4, steam stratification was recovered due to the continuous steam injection. Higher helium concentration was later observed in the lower part of Vessel 1. In Phase 5, the second activation of the spray led to a re-homogenisation of the atmosphere in Vessel 1. In this phase, the higher temperature spray (85°C) test showed a lower de-pressurisation rate (0.11 bar compared to 0.45 bar) with very little impact on the overall gas distribution. The change in cooler geometry,

hindering the flow through the cooling coils only affected the local concentration in the cooler and reduced the heat removal capacity. The impact on the overall gas distribution, however, was negligible

From a safety point of view it can be pointed out that – following the first spray activation – the helium to air concentration ratio remained constant. Additional spray activation only affected the steam content through condensation processes and therefore the overall pressure of the facility.

HP5 series: Thermal stratification build-up in a water pool with/without cooler

In both PWRs and BWRs water pools are used as heat sinks for condensing steam during a (postulated) accident. One main concern associated with the performance of suppression pool in general is the reduction of heat sink capability in the case of thermal stratification under certain steam injection conditions. The HP5 series consisted in seven experiments with the focus on i) the formation of a thermal stratification in the first phase of the experiment in a water pool caused by steam venting at a low flow rate through a vertical sparger and ii) the thermal stratification break-up and homogenisation in a second phase due to a) steam or b) steam/helium venting at a higher flow rate or c) water injection into the pool through a horizontal nozzle.

All the experiments starting at room temperature show a slightly higher temperature growth rate during the stratification build-up (Phase 1) compared with the experiment starting at elevated temperatures. For experiments starting at elevated temperatures the available energy is distributed across larger amounts of water which results in a weaker temperature growth rate on average for these experiments.

For the pure steam venting we find that the momentum of the steam has a significant effect onto the mixing efficiency and the mixing time during Phase 2, i.e. the higher the steam mass flow rate the faster the mixing and, additionally, for a given steam mass flow rate, we found the mixing at elevated pool temperatures more efficient compared with lower pool temperatures. The water mass flow rate of 2 kg/s at 27 °C through the injection nozzle is more efficient to homogenise the pool temperature at elevated temperatures than a higher water mass flow rate of 3 kg/s with 26 °C at a lower pool temperature. The addition of a non-condensable gas (helium) to the steam injected enhances the mixing and temperature homogenisation dramatically, such that Phase 2 became the shortest in the entire experimental series HP5.

HP6 series: Natural circulation flow induced by opening hatches and effect on safety systems

Natural circulation was studied in the HP6 series in a two-room containment type (inner, inaccessible area, and outer, accessible area) where large flow loops can form between the inner and the outer zone. These zones are separated during the normal operation. In the case of an accident they become connected by opening of rupture discs and convective foils at the top of the steam generator towers, and, in some designs, dampers between the bottom of the annular region and the inner rooms. Extensive scoping calculations have shown the similarity between two-room containment behaviour and the PANDA facility considering four vessels connected adequately. The two interconnecting pipes of the lower Vessels 3 and 4 were closed by lids. Vessel 4 represents the steam generator tower while Vessel 3 represents the lower part of the annular region of the containment. A small aperture was made in the cover of the lower interconnecting pipe, to represent the mixing damper. The two upper vessels – representing the containment

dome – were connected to the lower vessels through already existing lines (vacuum breaker lines and main vent line).

The scenario consisted of four phases. In Phase 1, a high steam flow rate was injected in Vessel 4. After the relaxation Phase 2, helium was injected in Vessel 4. Finally in Phase 4 no fluid was added to the system until the end of the test.

Two tests addressing conditions occurring under some accident conditions in various PWR designs such as KONVOI or EPR were performed to inspect the effect of the natural circulation flow on the homogenisation of the hydrogen distribution (simulated with helium); one with and one without simulated damper (by closing the aperture of the lower IP). This second configuration is also relevant for the natural circulation loop that might be encountered in a PHWR between the two fuelling machine vaults and the pump room.

The results showed that a two-room containment (TRC) mixing scenario can be represented in the PANDA facility and the following observations were made. With the mixing damper open, a global natural circulation loop forms over the four vessels (4, 2, 1 and 3) whereas with closed damper, the natural circulation loop is established only between three vessels (4, 2 and 1). Once created, the natural circulation loops persisted beyond the specified duration of the test. The open damper has a strong effect onto the helium content in Vessel 4 (SG tower); with the open damper we found three times less helium in Vessel 4 at the end of the experiment compared to the experiment with the closed damper. However, with the open damper the final natural circulation loop did not mobilise the upper parts of both Vessel 1 and 2, where strong helium stratification remained (15 and 10% vol. resp.). With closed damper the final natural circulation loop mobilised the gas atmosphere in all three vessels 1, 2 and 4 and the final helium concentration was well mixed in Vessel 4 and the top of Vessel 1 and 2 (~10% vol.), but almost no activity was observed in Vessel 3.

MISTRA

Experiments of the first three series of the Project were conducted in the MISTRA facility operated by CEA. The erosion of a stratified layer by the use of a diffuse buoyant jet was studied for both air/helium and air/steam/helium mixtures in the HM1 series. These tests intend to provide the helium mixing transient as well as the details of the temperature field during the erosion process. The second and the third series – HM2 and HM3 – were dedicated to increase the knowledge about the mobilisation capabilities of heat sources and about the extraction of light gas trapped below the entrance level of these devices.

HM1 series: Jet/plume interacting with flow obstruction

The first HM1-1 test put focus onto the erosion of a stratified layer by a diffuse and buoyant jet of hot air to obtain detailed results as the overall erosion time and the evolution of the associated temperature field. The experimental results were used for a blind benchmark exercise in which seven partner institutes participated. With the standard k- ϵ model used by all the participants, the results of the calculation showed a relatively good prediction of the mixing time (+/- 30% spreading). In the open phase of the exercise, mesh adjustment and the use of more sophisticated turbulence models, such as the SST-k-w model or dynamic calculation of the turbulent Schmidt number, greatly reduced the spread of the results. In this computational exercise, the predicted temperature field was generally overestimated. This results in additional tests to measure the relative humidity (possible effect of the radiative absorption of the small amount of

water vapour) and to obtain more detailed measurements of the heating of the inner cylinder on which the hot jet impinges.

A counterpart test named HP1-1 was conducted in the PANDA facility with almost the same initial and boundary conditions except that a vertical plate was used in PANDA instead of the inner cylinder in MISTRA. An engineering analysis has shown the excellent control of the experimental initial and boundary conditions leading to almost the same mixing process in both facilities.

For the other tests of the HM1 series it was investigated how a diffused superheated steam jet erodes a helium/air/steam mixture at elevated pressure. The upper stratified layer was prescribed to conserve the Brunt-Väisälä frequency N from the HM1-1 tests and the injected flow rate of steam was adjusted to have the same injection Richardson number Ri_{inj} (HM1-3 test). Two other tests were performed: one without any injection (zero-test HM1-2) and one with a reduced flow rate (HM1-4) in order to provide a full coverage of the different mixing times. As expected, the slowest mixing time corresponds to the “natural” evolution of the stratified layer without any injection despite this mixing process was faster than pure molecular diffusion. Increasing the injection flow rate decreases the mixing time. Scaling with N and Ri_{inj} was not fully successful but the HM1 test series together with the HP1 test series offer a wide spectrum of parameter variations for CFD code benchmarking concerning the erosive capabilities of diffuse buoyant jets.

HM2 and HM3 series: Heat source (s) with flow obstruction

The other series HM2 and HM3 were dedicated to the important issue of light gas mobilisation by passive autocatalytic re-combiners (PARs). The PARs generate heat during operation which induces natural convection inside the containment. For the predicted transient of hydrogen consumption at the lower part of the containment caused by thermal stratification, large discrepancies between the modelling results became obvious during the PARIS numerical benchmark organised within the SARNET framework. Similar conclusions were made after the SETH-2 Project in which computer code benchmarks were conducted based on experiments performed in the PANDA facility. Full scale PAR performance tests conducted in the German THAI facility have also demonstrated that a thermal stratification resulting from PAR operation affects the hydrogen mixing inside a compartment. Consequently, dedicated experiments were proposed to measure the time scale related to this intermediate transfer between convection and molecular diffusion.

The MISTRA experiments addressed the capability of the convective flow induced by the heat source to reach regions with a high helium content which can form in the lower region of a compartment and below a PAR. The PAR operation was simulated by electrical heaters. The tests provide data on natural circulation flow and on the overall distribution of helium in different regions. Two test series were conducted with one (HM2) or two (HM3) heat sources and a zero-test (HM2-0) without heat sources for comparison.

The helium-rich layer trapped in the lower part of the inner cylinder was created by heating the two upper condensers to generate a hot air layer at the top of the MISTRA facility. This was followed by slowly injecting a mixture of 10 vol. % of helium in air in the lower part of the inner cylinder. However, when the injection was stopped, the upper convection loop induced by the heating of both condensers continuously extracted helium from the bottom part of the facility; similar to the reverse erosion process demonstrated in

the previous HM1 tests. This transient mixing process was recorded in the zero-test (HM2-0).

The activation of the heaters was expected to have two opposite effects: a “pumping” one in which helium is extracted from the lower layers to the upper volume through the heater and a “confining” one because the hot plume issuing from the heater is competing with the upper convection loop driven by the condensers. Assuming axial symmetry, integration of the gas concentration measurements over different control volumes provides a global measure of the two effects. The fastest decrease of helium concentration in the lower part of the inner cylinder after the end of the injection was measured during the zero-test indicating the strong perturbing effect of the heater plume on the upper convection loop. This net effect was also measured by the increase of helium content in the upper part of the outer compartment. The weakening of the upper convection was the dominant contribution irrespective of the heater put into operation and irrespective of the heater location. The highest effect was recorded when the two heaters were in operation at the upper position. The transient increase of helium content in the upper part of the inner cylinder demonstrated that more helium stayed temporary in this volume during the heater operation because the net extraction to the upper volume of the MISTRA facility, involving the “pumping” effect and the erosion by the upper convection loop, was not compensating the supply from the upper part of the inner cylinder. Thus we can conclude that the heaters weakened the upper convection without providing the same extraction efficiency by the “pumping” effect. Accompanying analytical activities were performed. They included the development of heater models in computational fluid dynamics (CFD) codes for some participants and the computation of the previously described tests. The general trends of the measured results were captured by the CFD models despite the fact that some details were not fully reproduced. Additional efforts are still needed to enhance the confidence in the use of CFD codes for these complicated processes.

We have to point out that a high level of reproducibility of the test results was achieved during this project. This provides a high confidence level for the measured phenomena necessary for CFD-grade experiments and CFD code validation and benchmarking activities.

To conclude, a fruitful collaborative work was achieved during this project between the two operating agents from one side and participants and the OAs, on the other side.

2. Conclusions and recommendations

The Project was carried out in the PANDA and MISTRA facilities to increase the understanding of safety relevant thermal-hydraulic phenomena associated with hydrogen distribution in the containment. The hydrogen and air mixtures can become flammable or explosive and consequently may threaten containment integrity or damage safety systems.

The experiments conducted within Phase 1 of the Project form a toolbox that can be used for code validation purposes. For example, the results obtained by the participants during the blind benchmarks for the HP1 series using the best estimate model show that a combination of meshes and modelling approaches can result in a wide spread of results, with the quality of the results not always being improved using a model selection that proved to be successful for other configurations and test conditions. These conclusions are also partially valid for the benchmark exercises carried out for the HM1 series. However, in the open phase, the use of more sophisticated turbulence models reduced the dispersion of erosion time results. It was shown that the accurate modelling of the heat transfer in structures is mandatory to correctly predict the gas flow trajectories. To improve the predictive nature of the computational fluid dynamics (CFD) tools, all of these calculation exercises were very enriching for the partners of the Project.

The present experiments have proven that – depending on the geometrical configuration – the resulting flow field for a jet that may form from a tube break can vary dramatically and result in unexpectedly large differences in the evolution of the gas distribution, requiring additional assessment of meshing strategies and turbulence model selection. It is therefore recommended to extend the data base by considering more complicated flow geometries resembling those of nuclear containment internal structures.

The analytical activities performed showed an improvement by modelling the radiative heat transfer in several cases. However, because the parametric variation of the tests in the Project was not made to evaluate radiative heat transfer as a separate effect, it is recommended that additional tests be performed before drawing conclusions on this issue.

During the HP2/3 series, it was demonstrated that the simultaneous activation of the upper and the lower heaters accelerated the break-up of the helium stratification formed above the jet injection level, while also homogenising the entire Vessel 1 at the end of the test. The strong *inclined* plume created by the lower heater and the horizontal flow are the characteristic features that could be the focus of detailed analysis with computational codes. The HM2/3 series showed that the mobilisation of the helium trapped below the heater inlet is a slow process and that the plumes emerging from the heater outlets can strongly disrupt a counter-current natural convection loop. These complex situations were very difficult to simulate, thus providing exactly the type of experiments necessary to enhance the predictive capabilities of CFD tools.

The combined effect of spray and cooler activation (HP4 series) has indicated that the helium to air concentration ratio remained constant after the first spray activation. Additional spray activation only affected the steam content through the condensation

processes and therefore the overall pressure of the facility, which is an important result from a safety point of view.

As a result of the multi-phase nature of the venting process, the analysis of the present pool experiments (HP5) have revealed that the prediction of the thermal-hydraulic phenomena using advanced LP and 3D codes remains a challenging task. It is therefore recommended to extend these experiments by considering different water levels, different sparger immersion depths and by using blow down pipes for the steam release.

The results for the natural circulation experiments (HP6) showed that a TRC mixing scenario can be represented in the PANDA facility. With the mixing damper open, a global natural circulation loop forms over the four vessels (4, 2, 1 and 3), whereas with closed damper the natural circulation loop is established only between three vessels (Vessels 4, 2 and 1).